

window[®] Life PLUS

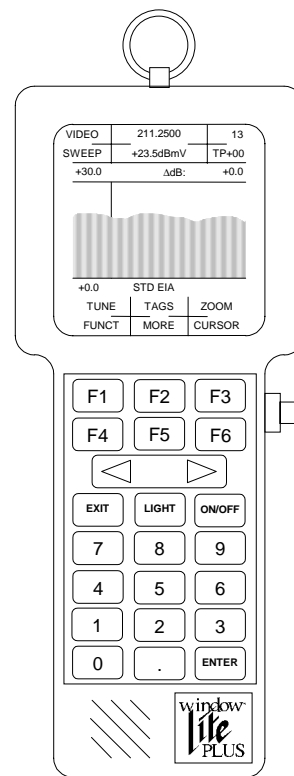

Model 100280-007

User's Guide



We set the standards.

1350 Port Republic Road -- Post Office Box 1106
Harrisonburg, VA 22801 USA
USA Toll Free: (800) 336-9681
Phone: (540) 434-5965
Fax: (540) 432-9794
email: marketing@comsonics.com

CSI Doc. 100977-001, Rev A

Warranty

ComSonics, Inc. warrants this product to be free of material and workmanship defects for a period of two years from the original date of shipment.

Remedies provided under Warranty are exclusive and in lieu of all other warranties express or implied. The liability to ComSonics is limited to product repair or replacement at the discretion of ComSonics. ComSonics shall not be held liable for any incidental or consequential damages.

The following are not covered by this warranty:

- 1) Parts or components not supplied by ComSonics, or parts or components that have been modified.
- 2) Any product or part failure that results from accident, abuse, misuse, neglect, or unauthorized repairs or modifications by individuals other than ComSonics personnel.
- 3) Failures caused by use of this product in extreme climates or moisture conditions.
- 4) WindowLite PLUS Battery Pack

Technical Support

ComSonics maintains a Technical Support Service for customer convenience. Should the need arise, a Technical Support Representative can be reached by Phone (1-800-336-9681, 1-540-434-5965), Fax (1-540-432-9794), or Email (tech-support@comsonics.com).

Return Information

Products returned for repair, calibration, etc., must be safely packed. Please enclose information on the reason for return. Ship the material prepaid.

All material in this manual is the property of ComSonics, Inc. and is protected under the United States copyright law. No material shall be reproduced or used in any form or by any means (graphic, electronic, or mechanical, including photocopying, recording, taping, or information storage and retrieval systems) without the written permission of:

ComSonics, Inc.
1350 Port Republic Road
Post Office Box 1106
Harrisonburg, Virginia 22801 USA
Phone: (540) 434-5965 USA Toll Free: (800) 336-9681
Fax: (540) 434-9847
Email: marketing@comsonics.com

WindowLite is a trademark of ComSonics, Inc.

Copyright © 1997 ComSonics, Inc. Doc No. 100977-001 Rev. A

Menu Navigator

WindowLite PLUS

ComSonics, Inc. - ©1991-1997 v 2.0

OPERATOR GUIDE

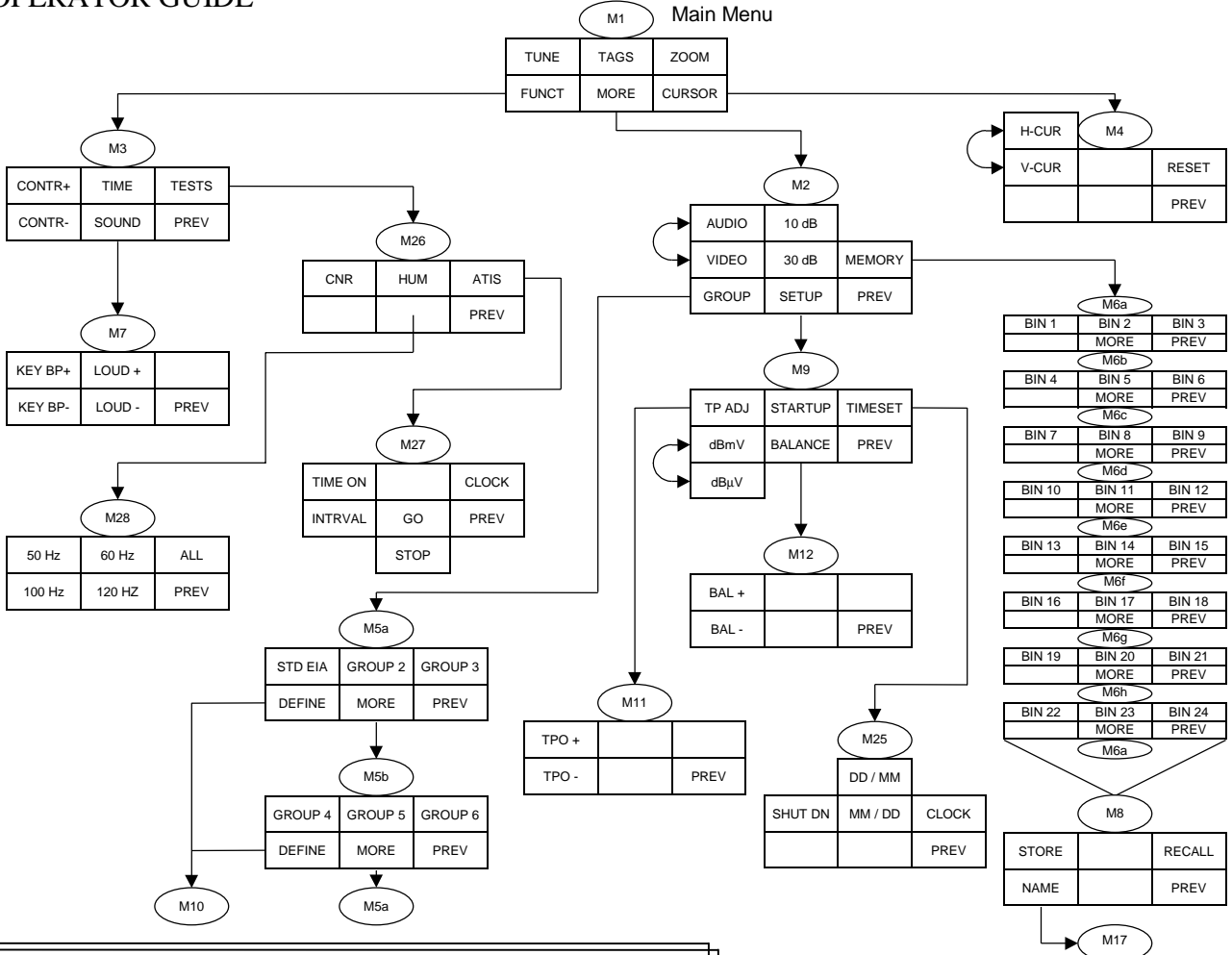

CONFIGURATION GUIDE

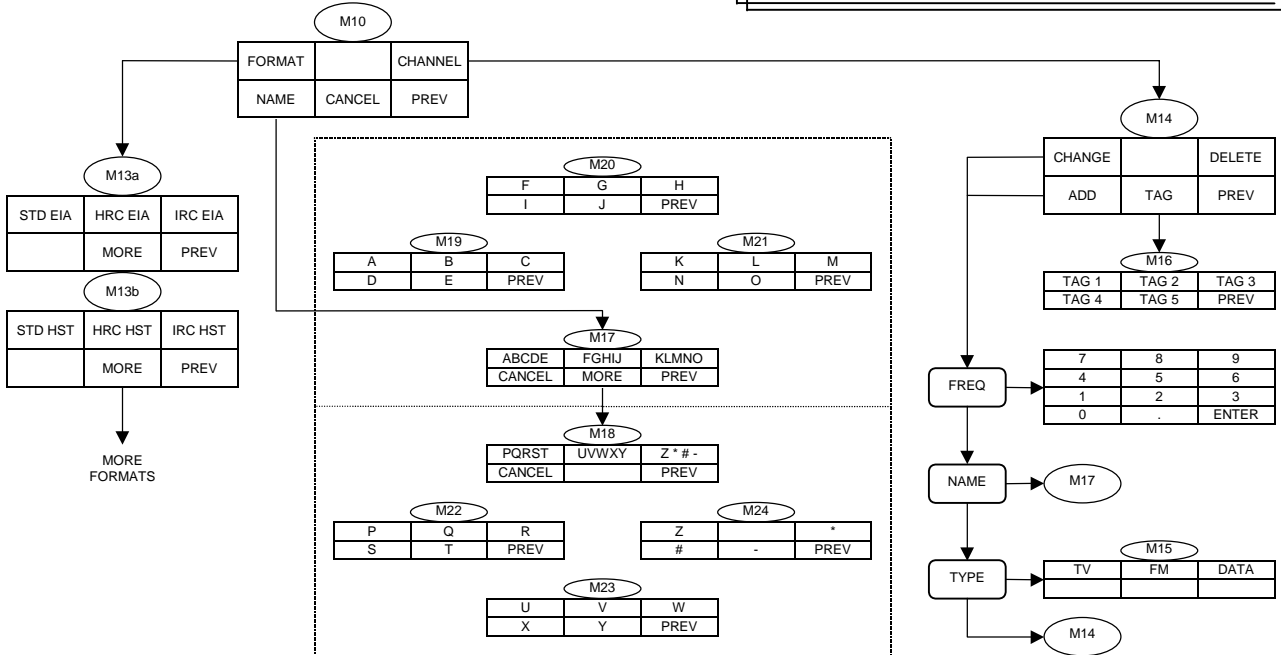

Specifications

General

<i>Frequency Range</i>	5 ~ 860 MHz
<i>Input Level Range</i>	-45 dBmV ~ +60 dBmV
<i>Input Impedance</i>	75 Ω nominal
<i>IF Passband</i>	180 kHz
<i>Graph Display Range</i>	30 dB or 10 dB, user selectable
<i>Display Units:</i>	
<i>Absolute</i>	dBmV, dB μ V
<i>Relative</i>	percent, dB
<i>Display Resolution</i>	0.1 dB, 0.1%
<i>Maximum RF Input Power</i>	1.0 Watt
<i>RF Input 50/60 Hz Isolation</i>	250 VAC
<i>Power Requirements</i>	6.0 watts maximum, supplied from a rechargeable 9.6 volt, 1.2 ampere-hour nickel-cadmium (Ni-Cd) battery pack

Signal Level

<i>Accuracy</i>	
68 °F (20 °C)	± 1.0 dB
0 °F ~ 120 °F (-18 °C ~ 49 °C)	± 1.5 dB

Carrier-to-Noise

<i>Accuracy</i>	
68 °F (20 °C)	± 1.5 dB
0 °F ~ 120 °F (-18 °C ~ 49 °C)	± 2.5 dB
<i>Maximum Dynamic Range</i>	50 dB (Input Level = +10 dBmV)

Low Frequency Disturbance (HUM)

<i>Accuracy</i>	
68 °F (20 °C)	± 0.5%
0 °F ~ 120 °F (-18 °C ~ 49 °C)	± 1.0%
<i>Range</i>	0.5% ~ 10%
<i>Passband</i>	50 Hz, 60 Hz, 100 Hz, 120 Hz, or 20 Hz ~ 2 kHz
<i>Input Range</i>	0 dBmV ~ +20 dBmV

Temperature Measurement

<i>Accuracy</i>	± 2°
<i>Range</i>	-40 °F ~ 180 °F (-40 °C ~ 82 °C)

Mechanical

<i>Operating Temperature</i>	0 °F ~ 120 °F (-18 °C ~ 49 °C)
<i>Storage Temperature</i>	-20 °F ~ 150 °F (-29 °C ~ 66 °C)
<i>Operating Humidity</i>	0% ~ 100+%
<i>Storage Humidity</i>	0% ~ 90% (non-condensing)
<i>Net Weight</i>	2.5 lb. (1.1 kg)
<i>Shipping Weight</i>	5.5 lb. (2.5 kg)
<i>Dimensions (maximum)</i>	10.6 x 4.0 x 3.1 inches (269.2 x 101.6 x 77.7 mm)

Specifications subject to change without notice

Table of Contents

Warranty, Support, and Return Information.....	Inside Cover
Menu Navigator.....	i
Specifications	ii
Table of Contents	iii
Table of Figures.....	vii
Table of Tables.....	viii
Section 1	
1 Getting Started.....	1
1.1 Unpacking the Unit	1
1.1.1 Battery Care.....	1
1.1.2 Removing and Installing the Battery Pack	1
1.1.3 Charging the Battery Pack.....	2
1.2 Mechanical Features.....	3
1.2.1 Accuracy Features / Calibration	4
1.3 Accessories Table.....	5
1.4 Personality Features	5
Section 2	
2 Operational Features.....	6
2.1 Introduction	6
2.1.1 Screen Display.....	6
2.1.2 SoftKeys	8
2.1.3 Battery Usage	9
2.1.4 Groups	10
2.1.5 Tags	10
2.1.6 Memory Bins.....	10
2.1.7 Formats.....	11

Table of Contents

2.2 Personality	12
2.2.1 Personality Configuration Table.....	12
2.2.2 Auto Shut-Down Time Set	13
2.2.3 Display Contrast	14
2.2.4 Key Beep Loudness	15
2.2.5 StartUp Mode Define	16
2.2.6 Test Point Offset Select.....	17
2.2.7 Balance Adjust.....	18
2.2.8 Units of Measure Toggle	19
2.2.9 Date/Time Reset	20
2.2.10 Time Display	21
2.2.11 Date Format Select	22
Section 3	
3 Using the WindowLite PLUS.....	23
3.1 Controlling the Unit.....	23
3.1.1 Audio/Video Carrier Display Toggle	24
3.1.2 Display Range (10dB/30dB) Toggle	25
3.1.3 Listening to Channel Audio.....	26
3.1.4 Channel Audio Loudness	27
3.2 Groups	28
3.2.1 Selecting the Active Group	29
3.2.2 Initializing a Group with a new Format.....	30
3.2.3 Naming a Group	31
3.2.4 Delete a Channel within a Group	32
3.2.5 Add a Channel within a Group.....	33
3.2.6 Change Channel Frequency, Name, Type	34
3.2.7 Changing the Tags within a Group.....	35
3.3 Cursor Operations.....	36
3.3.1 Vertical/Horizontal Cursor Toggle.....	36
3.3.2 Horizontal Cursor Position/Reset.....	37
3.4 Tuning to a Channel	38
3.4.1 Channel Number Tuning	38
3.4.2 Channel Frequency Tuning.....	39
3.4.3 Arrow Key Tuning.....	39

Table of Contents

3.5 Selecting Operational Mode.....	40
3.5.1 Tags Mode Select.....	41
3.5.2 Tune Mode Select.....	42
3.5.3 Zoom Mode Select.....	43
3.5.4 Sweep Mode Select.....	45
3.5.5 Automatic Time Interval Sampling (ATIS) Mode Select.....	46
3.6 Making Measurements.....	47
3.6.1 Video Carrier Measurement.....	48
3.6.2 Peak-to-Valley Measurement.....	49
3.6.3 Audio Carrier Measurement.....	50
3.6.4 Carrier-to-Noise Measurement.....	52
3.6.5 Hum Measurement.....	54
3.6.6 Automatic Time Interval Sampling.....	56
3.7 Using the Memory.....	57
3.7.1 Memory Bin Store.....	57
3.7.2 Memory Bin Naming.....	58
3.7.3 Memory Bin Recall.....	59

Table of Contents

Section 4	
4 Miscellaneous	60
4.1 Format Sets	60
4.1.1 AUSTRAL - Australia	61
4.1.2 BCST US - US Off Air	61
4.1.3 BELGIUM - Belgium	62
4.1.4 CANADA - Canada	62
4.1.5 CHINA - China	63
4.1.6 DENMARK - Denmark	63
4.1.7 FRANCE - France	64
4.1.8 GERMANY - Germany	64
4.1.9 H.KONG - Hong Kong	65
4.1.10 HRC EIA - US HRC EIA	65
4.1.11 HRC HST - US HRC HIST	66
4.1.12 INDIA - India	66
4.1.13 IRC EIA - US IRC EIA	67
4.1.14 IRC HST - US IRC HIST	67
4.1.15 ISRAEL - Israel	68
4.1.16 ITALY - Italy	68
4.1.17 JAPAN - Japan	69
4.1.18 KOREA - Korea	69
4.1.19 N ZEAL - New Zealand	70
4.1.20 NETH 1 - Netherlands 1	70
4.1.21 NETH 2 - Netherlands 2	71
4.1.22 POLAND - Poland	71
4.1.23 REVERSE - Reverse Channel	72
4.1.24 STD EIA - US STD EIA	72
4.1.25 STD HST - US STD HIST	73
4.1.26 SWEDEN - Sweden	73
4.1.27 SWISS - Switzerland	74
4.1.28 TAIWAN - Taiwan	74
4.1.29 UK 1 - United Kingdom 1	75
4.1.30 UK 2 - United Kingdom 2	75
4.2 Glossary	76
4.3 European Community Declaration of Compliance	79

Table of Figures

Figure 1 - Battery Pack Removal and Installation.....	1
Figure 2 - Mechanical Features, Front View.....	3
Figure 3 - Mechanical Features, Side View	4
Figure 4 - General Screen Display	7
Figure 5 - SoftKeys and their Labels.....	8
Figure 6 - Battery Low Indicator	9
Figure 7 - Battery Dead Indicator.....	9
Figure 8 - Auto Shut-Down Time Set	13
Figure 9 - Display Contrast Steps.....	14
Figure 10 - Key Beep Loudness Steps.....	15
Figure 11 - StartUp Mode Define Steps.....	16
Figure 12 - Test Point Offset Select Steps	17
Figure 13 - Balance Adjust Steps	18
Figure 14 - Units of Measure Toggle Steps.....	19
Figure 15 - Date/Time Reset Steps.....	20
Figure 16 - Time Display Steps.....	21
Figure 17 - Date Format Select Steps.....	22
Figure 18 - Audio/Video Carrier Display Toggle Steps.....	24
Figure 19 - Display Range (10dB/30dB) Toggle Steps.....	25
Figure 20 - Listening to Channel Audio Steps	26
Figure 21 - Channel Audio Loudness Steps.....	27
Figure 22 - Selecting the Active Group Steps.....	29
Figure 23 - Initializing a Group with a New Format Steps	30
Figure 24 - Naming a Group Steps.....	31
Figure 25 - Delete a Channel within a Group Steps.....	32
Figure 26 - Add a Channel within a Group Steps	33
Figure 27 - Change Channel Frequency, Name, Type Steps.....	34
Figure 28 - Changing the Tags within a Group Steps	35
Figure 29 - Vertical/Horizontal Cursor Toggle Steps	36
Figure 30 - Horizontal Cursor Position Base Value Reset Steps	37
Figure 31 - Channel Number Tuning Steps.....	38
Figure 32 - Channel Frequency Tuning Steps.....	39
Figure 33 - Arrow Key Tuning Steps	39
Figure 34 - Tags Mode Select Steps.....	41
Figure 35 - Tags Mode Display.....	41
Figure 36 - Tune Mode Select Steps	42
Figure 37 - Tune Mode Display	42
Figure 38 - Zoom Mode Select Steps.....	43
Figure 39 - Zoom Mode Display, Domestic.....	43
Figure 40 - Zoom Mode Display, International	44

Table of Figures

Figure 41 - Sweep Mode Select Steps.....	45
Figure 42 - Sweep Mode Display.....	45
Figure 43 - Automatic Time Interval Sampling Mode Select Steps.....	46
Figure 44 - Video Carrier Measurement Steps.....	48
Figure 45 - Video Carrier Measurement Display.....	48
Figure 46 - Peak-to-Valley Measurement Steps.....	49
Figure 47 - Peak-to-Valley Measurement Display.....	49
Figure 48 - Audio Carrier Measurement Steps.....	50
Figure 49 - Audio Carrier Measurement Display.....	51
Figure 50 - Carrier-to-Noise Measurement Steps.....	52
Figure 51 - Carrier-to-Noise Measurement Display.....	53
Figure 52 - Hum Measurement Steps.....	54
Figure 53 - Hum Measurement Display 60 Hz.....	55
Figure 54 - Hum Measurement Display 50 Hz.....	55
Figure 55 - Start Time and Interval for ATIS Select Steps.....	56
Figure 56 - Memory Bin Store Steps.....	57
Figure 57 - Memory Bin Naming Steps.....	58
Figure 58 - Memory Bin Recall Steps.....	59

Table of Tables

Table 1 - Accessories.....	5
Table 2 - Term / Functions.....	6
Table 3 - Country Format.....	11
Table 4 - Personality Configuration.....	12
Table 5 - Topics.....	23
Table 6 - Controlling the Unit.....	23
Table 7 - Groups.....	28
Table 8 - Cursor Operations.....	36
Table 9 - Tuning to a Channel.....	38
Table 10 - Operational Modes.....	40
Table 11 - Making Measurements.....	47
Table 12 - Using the Memory.....	57
Table 13 - Country Format.....	60

1 Getting Started

The following sub-sections are provided to assist you in initially using your WindowLite PLUS.

1.1 Unpacking the Unit

The WindowLite PLUS, its charger, and all ordered accessories are included in a single shipping container designed to provide the maximum protection during shipment. Immediately upon receipt, inspect the container and contents for signs of physical damage. Notify the freight forwarder of any damage detected.

It is advisable to keep the original shipping container for use when returning the unit for its annual re-calibration.

1.1.1 Battery Care

The WindowLite PLUS is powered by a battery pack of nickel-cadmium cells. In order to receive the maximum benefit from them, care must be taken to ensure that the recommended operating practices are followed.

As supplied from ComSonics, the WindowLite PLUS battery pack is only partially charged. Before using the unit for a full day's operation, the battery pack must be charged for 4 to 6 hours.

1.1.2 Removing and Installing the Battery Pack

The battery back is accessed from the back of the WindowLite PLUS. NOTE: The hand strap needs to be loosened and moved out of the way prior to attempting removal or installation.

To remove a battery pack, squeeze its two recessed slides towards each other (see C in Figure 1). The pack should partially 'pop' out of the housing.

To install a battery pack, squeeze the battery pack into the unit (see B in Figure 1). When fully seated, the locking slides will secure the battery pack into place.

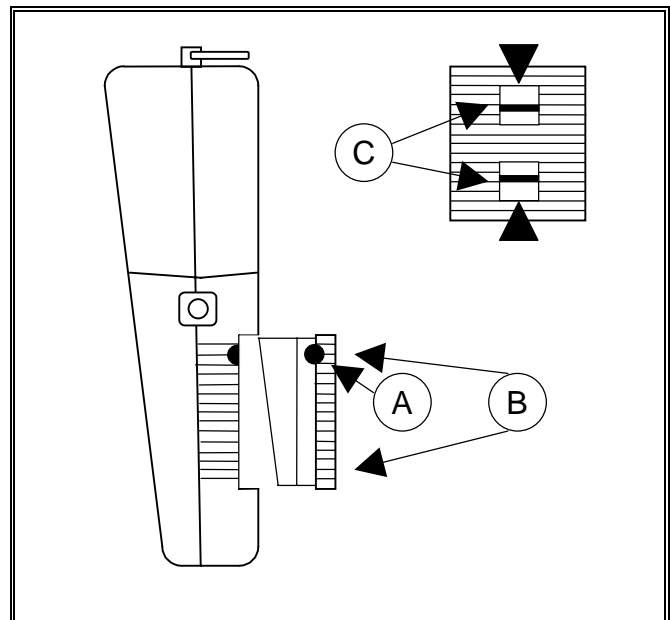

Figure 1 - Battery Pack Removal and Installation

1.1.3 Charging the Battery Pack

Battery packs can be charged either in the unit or out of the unit. The unit should be off during charging.

- 1) Insert charging plug into battery pack (see A in Figure 1)
- 2) Plug the charger AC plug into the AC Supply
- 3) Let charge for 4 to 6 hours.

Maximum recharge life is realized by using the battery pack until the WindowLite PLUS automatically shuts down after the Low Battery warning is issued, then recharging for 4 to 6 hours. Fully charged spare battery packs will ensure continued use of the unit.

WindowLite PLUS User's Guide

Section 1 - Getting Started

1.2 Mechanical Features

WindowLite PLUS electronics are protected from the outside elements by an ergonomically developed, high impact ABS plastic housing. Surface mount technology (SMT) allows complex high density circuits to reside on multi-layered printed circuit boards. Shock mounting the internal components provides maximum protection during normal field use of the unit.

For the following descriptions, please refer to Figures 2 and 3.

The keyboard and display are engineered to allow use in high moisture areas without adverse effect upon critical measurements. A threaded receptacle is provided to allow user replacement of the standard F-81 input connector or an optional female BNC connector.

A custom battery pack slides quickly and easily into the WindowLite PLUS handle. An adjustable strap provides a comfortable and flexible fit to the user's hand. For additional security, an optional utility lanyard can be attached to the ring on the top of the unit.

1 - Safety Ring - Allows the unit to be attached to a strand hook for hands free operation or to a utility lanyard for drop security.

2 - Liquid Crystal Display - a 128 x 128 pixel LCD which displays all information from the unit. A manually operated backlight is included for low ambient lighting use.

3 - Input Signal Connector - a user replaceable F-81 or BNC connector.

4 - LIGHT Key - manually turn the backlight on or off.

5 - ON/OFF Key - manually turn the unit on or off.

6 - ENTER Key - used to indicate the end of numeric input and other sequences.

7 - Speaker - outputs sound when tuning the audio carriers, sounds key beeps and warning beeps.

8 - Numeric Keys - used to input channel names and frequencies.

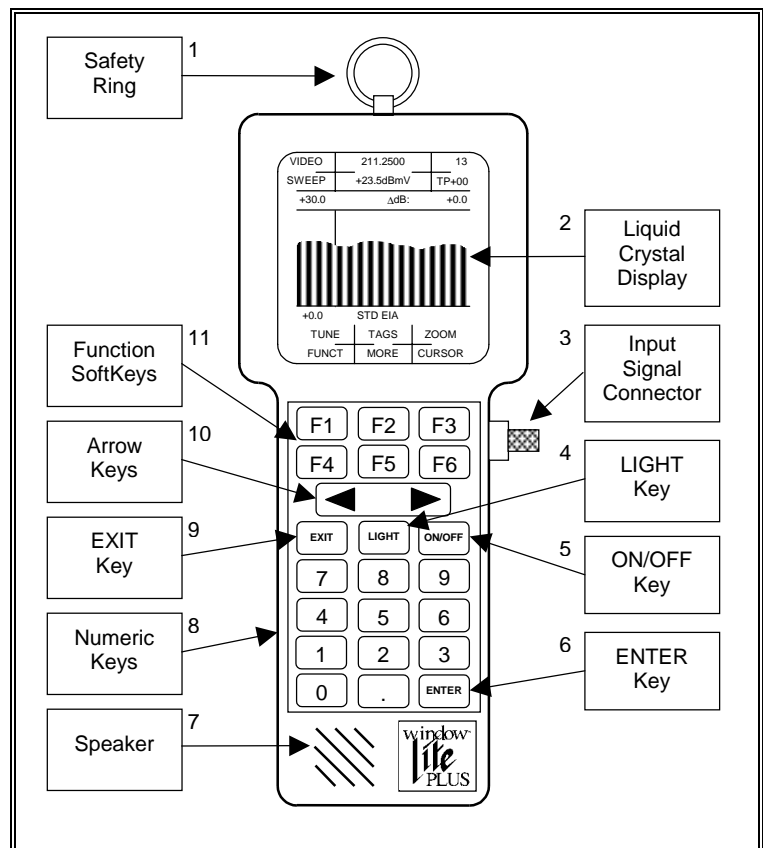

Figure 2 - Mechanical Features, Front View

WindowLite PLUS User's Guide

Section 1 - Getting Started

9 - EXIT Key - force the unit to its startup condition.

10 - ARROW Keys - provide the ability to control the cursors of the unit.

11 - Function SoftKeys - modes and functions are made available to the user through these keys.

12 - Accessory Module Port - used to attach add-on modules and PC communication interface cable.

13 - Adjustable Strap - used to provide a snug, comfortable handhold on the unit.

14 - Charger Input - used to both charge the battery and power the unit.

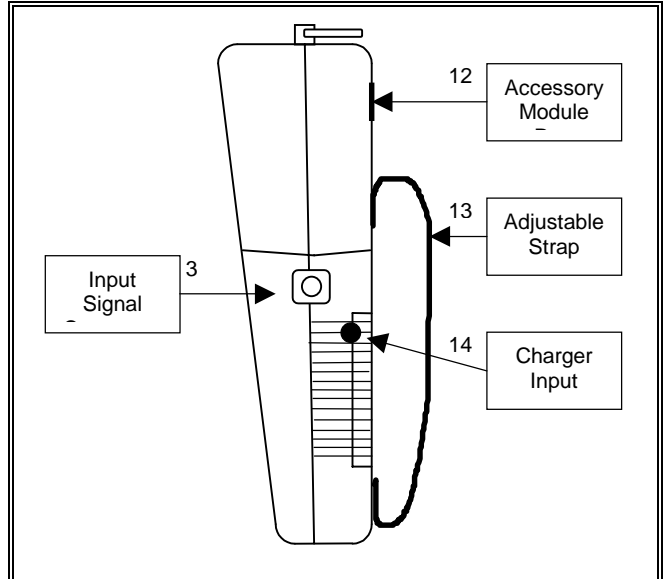

Figure 3 - Mechanical Features, Side View

1.2.1 Accuracy Features / Calibration

To ensure accuracy in the WindowLite PLUS, ComSonics, Inc. uses the most modern techniques designed specifically for CATV equipment development and manufacture. Each WindowLite PLUS unit is individually calibrated for signal level over frequency and temperature during manufacture in ComSonics' computer controlled calibration facilities.

Each WindowLite PLUS is carefully characterized at the factory before shipping. It is possible that internal circuitry aging will cause slight inaccuracies to occur. To confirm original accuracy, it is recommended that each unit be returned to the factory or to a factory authorized calibration facility at time intervals not to exceed one year.

WindowLite PLUS User's Guide

Section 1 - Getting Started

1.3 Accessories

ComSonics provides a number of accessories to enhance the use and operation of the WindowLite PLUS.

Description	Part Number
Battery Pack	100329-001
Charger, 120 VAC (domestic use)	BB-522
Charger, 220-240 VAC (international use)	BB-526
Manual - User's Guide	100977-001
Holster (optional)	100326-001
Vehicle Charging Adapter (optional)	100358-001
Utility Lanyard (optional)	100380-001
BNC Connector, Replaceable (optional)	CC-701
F Connector, Replaceable (replacement)	CC-699
Protective Softcase (optional)	100409-001
Docking Station (optional)	100401-001
Interface Cable	100468-001

Table 1 - Accessories

1.4 Personality Features

Cable systems world-wide vary in numerous ways:

- Number and frequency of active television channels
- Number and frequency of FM frequencies
- Number and frequency of Data carriers.
- Offset of Audio frequency to Video frequency

Individual technician's needs and preferences also vary:

- Prefer to observe several specific channels on start up.
- Must conveniently switch from one cable system to another.
- Prefer to hear or not hear an audible tone with each key stroke.
- Need to automatically compensate for a test point offset.

The WindowLite PLUS addresses all of the above plus many more specific needs of the user and the cable system. This ability to change its personality makes the WindowLite PLUS a truly valuable tool.

2 Operational Features

2.1 Introduction

The broad functionality of the WindowLite PLUS requires some introduction of terms and functions as follows:

Term/Functions	Sub Section	Page #
Screen Display	2.1.1	6
SoftKeys	2.1.2	8
Battery Usage	2.1.3	9
Groups	2.1.4	10
Tags	2.1.5	10
Memory Bins	2.1.6	10
Formats	2.1.7	11
Personality	2.2	12

Table 2 - Term / Functions

2.1.1 Screen Display

Information is displayed in specific areas on the screen of the WindowLite PLUS. The following is a general reference to the location and use of the screen areas.

- 1 - Audio/Video display mode toggle. It is either AUDIO or VIDEO.
- 2 - Vertical Cursor Amplitude. This is the level of the carrier at the cursor.
- 3 - Frequency of the channel at the vertical cursor.
- 4 - Name of the channel at the vertical cursor.
- 5 - Current Test Point Offset value.
- 6 - Output Line. This field displays output values depending upon the current function mode of the unit. The title of the field is displayed with the numeric outputs HUM, CNR, Δ dB, etc.
- 7 - Vertical Cursor. The visual indicator of the channel currently being observed.

WindowLite PLUS User's Guide

Section 2 - Operational Features

- 8 - Horizontal Cursor Reference. The base value used in Δ dB calculations.
- 9 - Bar Graph Display Area. The area where graphic displays appear.
- 10 - Memory Bin Name and data entry area. The area where the name of the current bin is displayed or where keyboard entries are displayed.
- 11 - SoftKey Labels. The labels that are associated with the function keys F1 through F6.
- 12 - Group Name. The name of the currently active group.

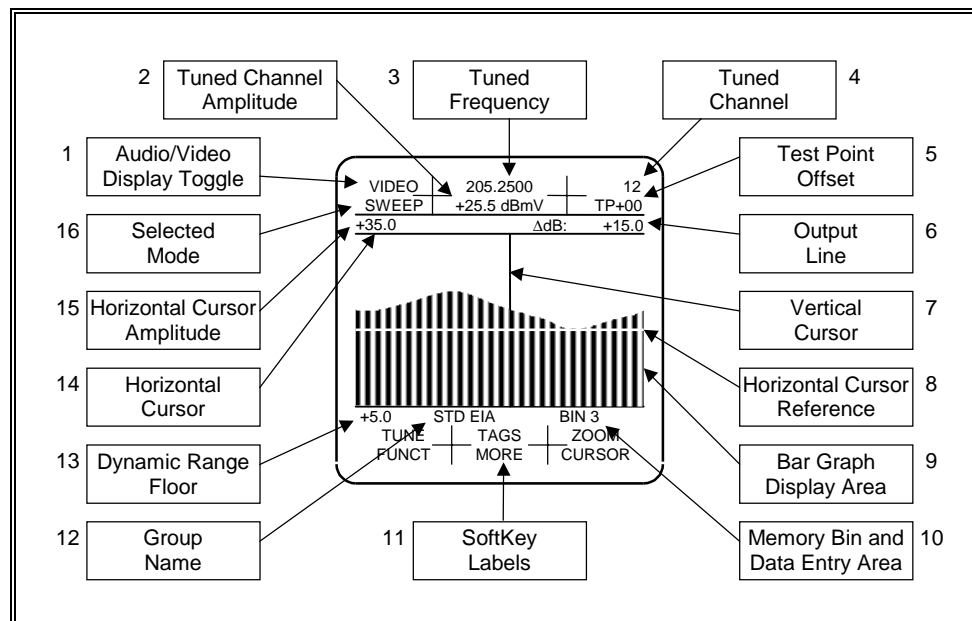

Figure 4 - General Screen Display

- 13 - Dynamic Range Floor. This is the amplitude of the base line displayed.
- 14 - Horizontal Cursor. The current position of the horizontal cursor.
- 15 - Current Horizontal Cursor Amplitude. The amplitude level at the position of the horizontal cursor.
- 16 - Selected Mode - this is the mode that is currently active. It can be SWEEP, TUNE, ZOOM or TAGS.

WindowLite PLUS User's Guide

Section 2 - Operational Features

2.1.2 SoftKeys

In the WindowLite PLUS, the function keys can assume different meanings depending upon the current status of the unit. Consequently, they are termed SoftKeys. This in contrast to the other keys on the unit which always have the same action.

There are 6 function keys labeled F1, F2, F3, F4, F5, and F6. At the bottom of the display screen, there are 6 associated message areas. The message area will always contain a description of the current function of the key. Should the message area be blank, then the SoftKey will have no associated action.

Thus, in this figure, the unit is in TAGS mode. Pressing the SoftKeys will result in the following:

- F1** - go into TUNE mode.
- F2** - go into TAGS mode.
- F3** - go into ZOOM mode.
- F4** - change the SoftKeys to the FUNCTION menu.
- F5** - change the SoftKeys to the MORE menu.
- F6** - change the SoftKeys to the CURSOR menu.

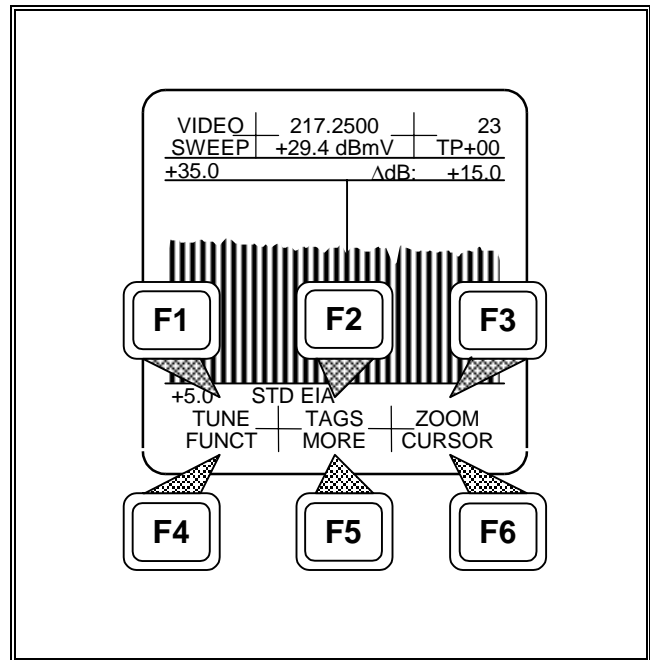

Figure 5 - SoftKeys and their Labels

WindowLite PLUS User's Guide

Section 2 - Operational Features

2.1.3 Battery Usage

The battery pack in the WindowLite PLUS, as is true with all batteries, has a finite usage time before it needs to be recharged.

The battery level bar graph indicates when recharging is necessary.

When the battery pack's charge is low a warning message BATTERY LOW appears on the screen in the output line.

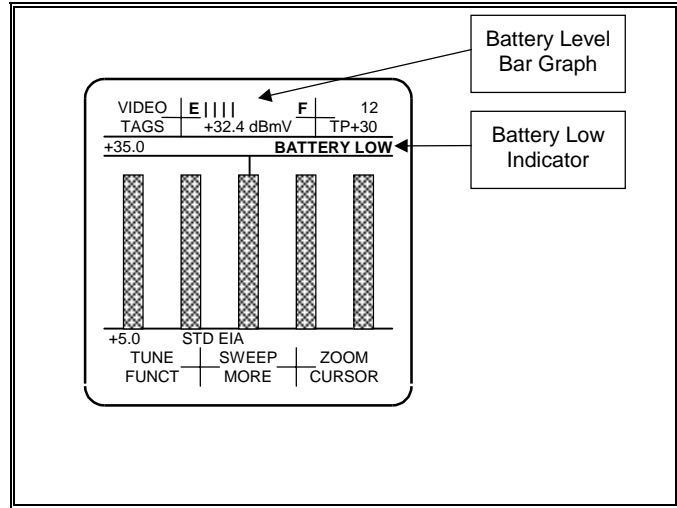

Figure 6 - Battery Low Indicator

Shortly thereafter, if the battery pack is not recharged, a BATTERY DEAD message appears in the middle of the screen. Then the unit shuts itself down.

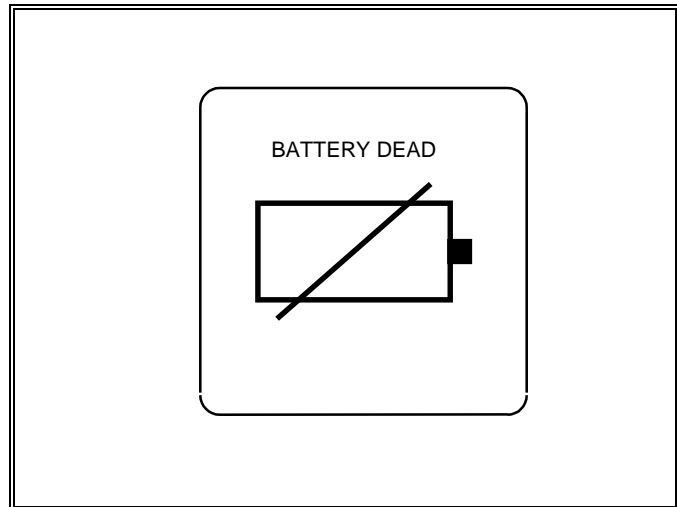

Figure 7 - Battery Dead Indicator

2.1.4 Groups

There are 6 Groups in the WindowLite PLUS. Each Group contains specific information on a set of 5 to 128 channels. In this definition, a channel is either a TV channel, an FM carrier or a data carrier. The information maintained on each channel is its name, its video carrier frequency and its audio carrier frequency. Audio carriers are automatically included with TV channels based on the *audio offset* for the format of the group. For information on formats, see Section 4.1 Format Sets, page 60. FM and data carriers are single frequency channels and do not have associated audio carriers.

FM and data carriers are displayed and available for measurement only in the audio carrier mode. See Section 3.6.3 Audio Carrier Measurement, page 50.

Initially, each of the 6 Groups is set to the Standard EIA Format which is listed in Section 4.1.24 on page 72. Each group can be changed to any of the standard formats stored in the WindowLite PLUS' memory at the factory. They can then be modified by the user to make a customized group.

2.1.5 Tags

Within each Group, 5 channels are designated Tags channels. These 5 channels will be the only ones displayed when the unit is in the Tags sweep mode. Since only 5 channels are being swept, a faster display update is achieved. The channels referenced as Tags can be changed by the user.

Initially, the Tags of each of the 6 Groups are set to those of the default values associated with the Standard EIA Format which is listed in Section 4.1.24 on page 72.

2.1.6 Memory Bins

The WindowLite PLUS contains 24 memory bins. These memory bins are used to store a full set of measurements, time, date, carrier-to-noise, hum, temperature and scaling information. At any time, the user can cause the current readings of the Group being observed to be stored in any bin. The readings thus stored can be reviewed at a later time. The memory bins are in the non-volatile memory of the unit and as such their contents are preserved when the unit is turned off.

Detailed information on the use of the memory bins can be found in Section 3.7 which starts on page 57.

WindowLite PLUS User's Guide

Section 2 - Operational Features

2.1.7 Formats

Formats are factory defined channel information sets that can be used to initialize any Group in the unit. ComSonics, Inc. provides many different Format sets to meet the needs of cable systems around the world. Others will be added as needed.

SoftKey Label	Description	Page #
AUSTRAL	Australia	61
BCST US	US Off - Air	61
BELGIUM	Belgium	62
CANADA	Canada	62
CHINA	China	63
DENMARK	Denmark	63
FRANCE	France	64
GERMANY	Germany	64
H.KONG	Hong Kong	65
HRC EIA	US HRC EIA	65
HRC HST	US HRC Historical	66
INDIA	India	66
IRC EIA	US IRC EIA	67
IRC HST	US IRC Historical	67
ISRAEL	Israel	68
ITALY	Italy	68
JAPAN	Japan	69
KOREA	Korea	69
N ZEAL	New Zealand	70
NETH 1	Netherlands 1	70
NETH 2	Netherlands 2	71
POLAND	Poland	71
REVERSE	Reverse Channel	72
STD EIA	US Standard EIA	72
STD HST	US Standard Historical	73
SWEDEN	Sweden	73
SWISS	Switzerland	74
TAIWAN	Taiwan	74
UK 1	United Kingdom 1	75
UK 2	United Kingdom 2	75

TABLE 3 - Country Format

WindowLite PLUS User's Guide

Section 2 - Operational Features

2.2 Personality

2.2.1 Personality Configuration Table

The following is a table of the items that the user can change to affect the personality of the WindowLite PLUS. The startup value of these personality items can be reset by the user.

Item	Factory Default	Range	Your Unit	Sub Section	Page #
Shut Down Time out	6 mins	0 to 59 mins step 1 min 0 = no shutdown		2.2.2	13
Display Contrast	medium	Dark to Light		2.2.3	14
Key Beep Loudness	medium	Off to Loud		2.2.4	15
Startup Mode	Sweep	Tags, Tune, Zoom, Sweep		2.2.5	16
Test Point Adjustment	0 dB	0 dB, 10 dB, 20 dB, 30 dB		2.2.6	17
Balance	0 dB	-5.0 dB to +5.0 dB (step 0.1)		2.2.7	18
Units of Measure	dBmV	dBmV or dB μ V		2.2.8	19
Date/Time Reset	1/1/92	DD = 1-31 MM = 1-12 YY = 00-99 HH = 1-24 MM = 0-59		2.2.9	20
Group 1	STD EIA	See Section 2.1.5 on page 10		3.2	28
Group 2	STD EIA	"		"	"
Group 3	STD EIA	"		"	"
Group 4	STD EIA	"		"	"
Group 5	STD EIA	"		"	"
Group 6	STD EIA	"		"	"

Table 4 - Personality Configuration

WindowLite PLUS User's Guide

Section 2 - Operational Features

2.2.2 Auto Shut-Down Time Set

To conserve the battery, an automatic shut-down timer is incorporated in the WindowLite PLUS. When activated, the unit shuts itself off after the designated time expires. Pressing any key resets the starting time of the timer.

This scenario shows how to reset the shut-down time interval.

SoftKey Menu	Press Key	Results						
<table border="1"> <tr> <td>TUNE</td> <td>TAGS</td> <td>ZOOM</td> </tr> <tr> <td>FUNCT</td> <td>MORE</td> <td>CURSOR</td> </tr> </table>	TUNE	TAGS	ZOOM	FUNCT	MORE	CURSOR	ON or EXIT	Main Menu is displayed.
TUNE	TAGS	ZOOM						
FUNCT	MORE	CURSOR						
<table border="1"> <tr> <td>TUNE</td> <td>TAGS</td> <td>ZOOM</td> </tr> <tr> <td>FUNCT</td> <td>MORE</td> <td>CURSOR</td> </tr> </table>	TUNE	TAGS	ZOOM	FUNCT	MORE	CURSOR	F5	
TUNE	TAGS	ZOOM						
FUNCT	MORE	CURSOR						
<table border="1"> <tr> <td>AUDIO</td> <td>10 dB</td> <td>MEMORY</td> </tr> <tr> <td>GROUP</td> <td>SETUP</td> <td>PREV</td> </tr> </table>	AUDIO	10 dB	MEMORY	GROUP	SETUP	PREV	F5	
AUDIO	10 dB	MEMORY						
GROUP	SETUP	PREV						
<table border="1"> <tr> <td>TP ADJ</td> <td>STARTUP</td> <td>TIMESET</td> </tr> <tr> <td>dBμV</td> <td>BALANCE</td> <td>PREV</td> </tr> </table>	TP ADJ	STARTUP	TIMESET	dB μ V	BALANCE	PREV	F3	
TP ADJ	STARTUP	TIMESET						
dB μ V	BALANCE	PREV						
<table border="1"> <tr> <td>SHUT DN</td> <td>MM/DD</td> <td>CLOCK</td> </tr> <tr> <td></td> <td></td> <td>PREV</td> </tr> </table>	SHUT DN	MM/DD	CLOCK			PREV	F1	MINUTES MM is displayed on the input line. MM is the current time to shut-down.
SHUT DN	MM/DD	CLOCK						
		PREV						
<table border="1"> <tr> <td></td> <td></td> <td></td> </tr> <tr> <td></td> <td>CANCEL</td> <td>PREV</td> </tr> </table>					CANCEL	PREV	Numeric Keys	Use the numeric keys and ENTER to modify the time. A value of 0 implies that no shutdown will occur.
	CANCEL	PREV						
<table border="1"> <tr> <td>SHUT DN</td> <td>MM/DD</td> <td>CLOCK</td> </tr> <tr> <td></td> <td></td> <td>PREV</td> </tr> </table>	SHUT DN	MM/DD	CLOCK			PREV	F6	
SHUT DN	MM/DD	CLOCK						
		PREV						
<table border="1"> <tr> <td>TP ADJ</td> <td>STARTUP</td> <td>TIMESET</td> </tr> <tr> <td>dBμV</td> <td>BALANCE</td> <td>PREV</td> </tr> </table>	TP ADJ	STARTUP	TIMESET	dB μ V	BALANCE	PREV	F2	Store the new shut-down time as the default STARTUP value.
TP ADJ	STARTUP	TIMESET						
dB μ V	BALANCE	PREV						
<table border="1"> <tr> <td>TP ADJ</td> <td>STARTUP</td> <td>TIMESET</td> </tr> <tr> <td>dBμV</td> <td>BALANCE</td> <td>PREV</td> </tr> </table>	TP ADJ	STARTUP	TIMESET	dB μ V	BALANCE	PREV	F6	
TP ADJ	STARTUP	TIMESET						
dB μ V	BALANCE	PREV						
<table border="1"> <tr> <td>AUDIO</td> <td>10 dB</td> <td>MEMORY</td> </tr> <tr> <td>GROUP</td> <td>SETUP</td> <td>PREV</td> </tr> </table>	AUDIO	10 dB	MEMORY	GROUP	SETUP	PREV	F6	
AUDIO	10 dB	MEMORY						
GROUP	SETUP	PREV						
<table border="1"> <tr> <td>TUNE</td> <td>TAGS</td> <td>ZOOM</td> </tr> <tr> <td>FUNCT</td> <td>MORE</td> <td>CURSOR</td> </tr> </table>	TUNE	TAGS	ZOOM	FUNCT	MORE	CURSOR		Main Menu is displayed.
TUNE	TAGS	ZOOM						
FUNCT	MORE	CURSOR						

Figure 8 - Auto Shut-Down Time Set

WindowLite PLUS User's Guide

Section 2 - Operational Features

2.2.3 Display Contrast

The WindowLite PLUS' LCD display contrast can be adjusted to meet the needs of the ambient lighting conditions.

The following scenario shows how to change display contrast.

SoftKey Menu	Press Key	Results						
<table border="1"><tr><td>TUNE</td><td>TAGS</td><td>ZOOM</td></tr><tr><td>FUNCT</td><td>MORE</td><td>CURSOR</td></tr></table>	TUNE	TAGS	ZOOM	FUNCT	MORE	CURSOR	ON or EXIT	Main Menu is displayed.
TUNE	TAGS	ZOOM						
FUNCT	MORE	CURSOR						
<table border="1"><tr><td>TUNE</td><td>TAGS</td><td>ZOOM</td></tr><tr><td>FUNCT</td><td>MORE</td><td>CURSOR</td></tr></table>	TUNE	TAGS	ZOOM	FUNCT	MORE	CURSOR	F4	
TUNE	TAGS	ZOOM						
FUNCT	MORE	CURSOR						
<table border="1"><tr><td>CONTR+</td><td>TIME</td><td>TESTS</td></tr><tr><td>CONTR -</td><td>SOUND</td><td>PREV</td></tr></table>	CONTR+	TIME	TESTS	CONTR -	SOUND	PREV	F1	Display darkens.
CONTR+	TIME	TESTS						
CONTR -	SOUND	PREV						
<table border="1"><tr><td>CONTR +</td><td>TIME</td><td>TESTS</td></tr><tr><td>CONTR -</td><td>SOUND</td><td>PREV</td></tr></table>	CONTR +	TIME	TESTS	CONTR -	SOUND	PREV	F4	Display lightens.
CONTR +	TIME	TESTS						
CONTR -	SOUND	PREV						
<table border="1"><tr><td>CONTR +</td><td>TIME</td><td>TESTS</td></tr><tr><td>CONTR -</td><td>SOUND</td><td>PREV</td></tr></table>	CONTR +	TIME	TESTS	CONTR -	SOUND	PREV	F6	Main Menu is displayed.
CONTR +	TIME	TESTS						
CONTR -	SOUND	PREV						

The Display Contrast is increased and decreased a small portion with each keypress. Once the maximum or minimum level is reached, additional depresses are ignored. Increasing the contrast to the maximum level will result in a totally dark screen. Decreasing the contrast to the minimum level will result in a totally blank screen. Note that the Display Contrast is a STARTUP definable parameter.

Figure 9 - Display Contrast Steps

WindowLite PLUS User's Guide

Section 2 - Operational Features

2.2.4 Key Beep Loudness

Key beep loudness is a personal preference of the user and is adjustable.

This scenario shows you how to adjust key beep loudness.

SoftKey Menu	Press Key	Results						
<table border="1"> <tr> <td>TUNE</td> <td>TAGS</td> <td>ZOOM</td> </tr> <tr> <td>FUNCT</td> <td>MORE</td> <td>CURSOR</td> </tr> </table>	TUNE	TAGS	ZOOM	FUNCT	MORE	CURSOR	ON or EXIT	Main Menu is displayed.
TUNE	TAGS	ZOOM						
FUNCT	MORE	CURSOR						
<table border="1"> <tr> <td>TUNE</td> <td>TAGS</td> <td>ZOOM</td> </tr> <tr> <td>FUNCT</td> <td>MORE</td> <td>CURSOR</td> </tr> </table>	TUNE	TAGS	ZOOM	FUNCT	MORE	CURSOR	F4	
TUNE	TAGS	ZOOM						
FUNCT	MORE	CURSOR						
<table border="1"> <tr> <td>CONT +</td> <td>TIME</td> <td>TESTS</td> </tr> <tr> <td>CONTR -</td> <td>SOUND</td> <td>PREV</td> </tr> </table>	CONT +	TIME	TESTS	CONTR -	SOUND	PREV	F5	Audio for current cursored channel comes on.
CONT +	TIME	TESTS						
CONTR -	SOUND	PREV						
<table border="1"> <tr> <td>KEY BP+</td> <td>LOUD+</td> <td></td> </tr> <tr> <td>KEY BP -</td> <td>LOUD -</td> <td>PREV</td> </tr> </table>	KEY BP+	LOUD+		KEY BP -	LOUD -	PREV	F1	Increase Loudness of Key Beep.
KEY BP+	LOUD+							
KEY BP -	LOUD -	PREV						
<table border="1"> <tr> <td>KEY BP+</td> <td>LOUD+</td> <td></td> </tr> <tr> <td>KEY BP -</td> <td>LOUD -</td> <td>PREV</td> </tr> </table>	KEY BP+	LOUD+		KEY BP -	LOUD -	PREV	F4	Decrease Loudness of Key Beep.
KEY BP+	LOUD+							
KEY BP -	LOUD -	PREV						
<table border="1"> <tr> <td>KEY BP+</td> <td>LOUD+</td> <td></td> </tr> <tr> <td>KEY BP -</td> <td>LOUD -</td> <td>PREV</td> </tr> </table>	KEY BP+	LOUD+		KEY BP -	LOUD -	PREV	F6, F6	Press F6 twice to display Main Menu.
KEY BP+	LOUD+							
KEY BP -	LOUD -	PREV						

Key Beep Loudness is a STARTUP definable parameter.

Figure 10 - Key Beep Loudness Steps

WindowLite PLUS User's Guide

Section 2 - Operational Features

2.2.5 StartUp Mode Define

Many of the factory default personality parameters can be changed and retained as startup parameters. Those parameters that can be set for startup are listed in Section 2.2.1, on page 12.

To set them for startup, set each parameter to its desired startup value and then follow this scenario. **Be careful, when the startup setup is completed, all of the above mentioned parameters will be set to their current settings.**

<i>SoftKey Menu</i>	<i>Press Key</i>	<i>Results</i>						
<table border="1"> <tr> <td>TUNE</td> <td>TAGS</td> <td>ZOOM</td> </tr> <tr> <td>FUNCT</td> <td>MORE</td> <td>CURSOR</td> </tr> </table>	TUNE	TAGS	ZOOM	FUNCT	MORE	CURSOR	ON or EXIT	Main Menu is displayed.
TUNE	TAGS	ZOOM						
FUNCT	MORE	CURSOR						
<table border="1"> <tr> <td>TUNE</td> <td>TAGS</td> <td>ZOOM</td> </tr> <tr> <td>FUNCT</td> <td>MORE</td> <td>CURSOR</td> </tr> </table>	TUNE	TAGS	ZOOM	FUNCT	MORE	CURSOR	F1, F2, F3 F4, F5, F6	Put unit into the desired startup configuration.
TUNE	TAGS	ZOOM						
FUNCT	MORE	CURSOR						
<table border="1"> <tr> <td>TUNE</td> <td>TAGS</td> <td>ZOOM</td> </tr> <tr> <td>FUNCT</td> <td>MORE</td> <td>CURSOR</td> </tr> </table>	TUNE	TAGS	ZOOM	FUNCT	MORE	CURSOR	F5	
TUNE	TAGS	ZOOM						
FUNCT	MORE	CURSOR						
<table border="1"> <tr> <td>AUDIO</td> <td>10 dB</td> <td>MEMORY</td> </tr> <tr> <td>GROUP</td> <td>SETUP</td> <td>PREV</td> </tr> </table>	AUDIO	10 dB	MEMORY	GROUP	SETUP	PREV	F5	
AUDIO	10 dB	MEMORY						
GROUP	SETUP	PREV						
<table border="1"> <tr> <td>TP ADJ</td> <td>STARTUP</td> <td>TIMESET</td> </tr> <tr> <td>dBμV</td> <td>BALANCE</td> <td>PREV</td> </tr> </table>	TP ADJ	STARTUP	TIMESET	dB μ V	BALANCE	PREV	F2	All current start up options (see below) are stored as the defaults.
TP ADJ	STARTUP	TIMESET						
dB μ V	BALANCE	PREV						
<table border="1"> <tr> <td>TP ADJ</td> <td>STARTUP</td> <td>TIMESET</td> </tr> <tr> <td>dBμV</td> <td>BALANCE</td> <td>PREV</td> </tr> </table>	TP ADJ	STARTUP	TIMESET	dB μ V	BALANCE	PREV	F6	
TP ADJ	STARTUP	TIMESET						
dB μ V	BALANCE	PREV						
<table border="1"> <tr> <td>AUDIO</td> <td>10 dB</td> <td>MEMORY</td> </tr> <tr> <td>GROUP</td> <td>SETUP</td> <td>PREV</td> </tr> </table>	AUDIO	10 dB	MEMORY	GROUP	SETUP	PREV	F6	
AUDIO	10 dB	MEMORY						
GROUP	SETUP	PREV						
<table border="1"> <tr> <td>TUNE</td> <td>TAGS</td> <td>ZOOM</td> </tr> <tr> <td>FUNCT</td> <td>MORE</td> <td>CURSOR</td> </tr> </table>	TUNE	TAGS	ZOOM	FUNCT	MORE	CURSOR		Main Menu is displayed.
TUNE	TAGS	ZOOM						
FUNCT	MORE	CURSOR						

Note that all definable startup parameters (TUNE, TAGS, ZOOM, SWEEP mode; Group; dBmV/dB μ V; Key Beep; Auto Shut Down Time; Test Point Adjust; Balance; Display Contrast; Audio/Video Carrier Display) are set with this procedure.

Figure 11 - StartUp Mode Define Steps

WindowLite PLUS User's Guide

Section 2 - Operational Features

2.2.6 Test Point Offset Select

The WindowLite PLUS allows the user to automatically compensate for test attenuation value. This is accomplished by adding values to the measurement of 5 to 30dB, in 5dB steps (5, 10, 15, 20, 25, or 30 dB). When the operator presses TP ADJ the existing offset is displayed on the output line and changes as the operator makes new selections.

The following scenario shows how to increase or decrease test point offset.

SoftKey Menu	Press Key	Results						
<table border="1"> <tr><td>TUNE</td><td>TAGS</td><td>ZOOM</td></tr> <tr><td>FUNCT</td><td>MORE</td><td>CURSOR</td></tr> </table>	TUNE	TAGS	ZOOM	FUNCT	MORE	CURSOR	ON or EXIT	Main Menu is displayed.
TUNE	TAGS	ZOOM						
FUNCT	MORE	CURSOR						
<table border="1"> <tr><td>TUNE</td><td>TAGS</td><td>ZOOM</td></tr> <tr><td>FUNCT</td><td>MORE</td><td>CURSOR</td></tr> </table>	TUNE	TAGS	ZOOM	FUNCT	MORE	CURSOR	F5	
TUNE	TAGS	ZOOM						
FUNCT	MORE	CURSOR						
<table border="1"> <tr><td>AUDIO</td><td>10 dB</td><td>MEMORY</td></tr> <tr><td>GROUP</td><td>SETUP</td><td>PREV</td></tr> </table>	AUDIO	10 dB	MEMORY	GROUP	SETUP	PREV	F5	
AUDIO	10 dB	MEMORY						
GROUP	SETUP	PREV						
<table border="1"> <tr><td>TP ADJ</td><td>STARTUP</td><td>TIMESSET</td></tr> <tr><td>dBμV</td><td>BALANCE</td><td>PREV</td></tr> </table>	TP ADJ	STARTUP	TIMESSET	dB μ V	BALANCE	PREV	F1	Current attenuation is displayed.
TP ADJ	STARTUP	TIMESSET						
dB μ V	BALANCE	PREV						
<table border="1"> <tr><td>TPO+</td><td></td><td></td></tr> <tr><td>TPO-</td><td></td><td>PREV</td></tr> </table>	TPO+			TPO-		PREV	F1	Increase the Test Point Offset.
TPO+								
TPO-		PREV						
<table border="1"> <tr><td>TPO+</td><td></td><td></td></tr> <tr><td>TPO-</td><td></td><td>PREV</td></tr> </table>	TPO+			TPO-		PREV	F4	Decrease the Test Point Offset.
TPO+								
TPO-		PREV						
<table border="1"> <tr><td>TPO+</td><td></td><td></td></tr> <tr><td>TPO-</td><td></td><td>PREV</td></tr> </table>	TPO+			TPO-		PREV	F6	
TPO+								
TPO-		PREV						
<table border="1"> <tr><td>TP ADJ</td><td>STARTUP</td><td>TIMESSET</td></tr> <tr><td>dBμV</td><td>BALANCE</td><td>PREV</td></tr> </table>	TP ADJ	STARTUP	TIMESSET	dB μ V	BALANCE	PREV	F6	
TP ADJ	STARTUP	TIMESSET						
dB μ V	BALANCE	PREV						
<table border="1"> <tr><td>AUDIO</td><td>10 dB</td><td>MEMORY</td></tr> <tr><td>GROUP</td><td>SETUP</td><td>PREV</td></tr> </table>	AUDIO	10 dB	MEMORY	GROUP	SETUP	PREV	F6	
AUDIO	10 dB	MEMORY						
GROUP	SETUP	PREV						
<table border="1"> <tr><td>TUNE</td><td>TAGS</td><td>ZOOM</td></tr> <tr><td>FUNCT</td><td>MORE</td><td>CURSOR</td></tr> </table>	TUNE	TAGS	ZOOM	FUNCT	MORE	CURSOR		Main Menu is displayed.
TUNE	TAGS	ZOOM						
FUNCT	MORE	CURSOR						

The Test Point Offset is a STARTUP definable parameter.

Figure 12 - Test Point Offset Select Steps

WindowLite PLUS User's Guide

Section 2 - Operational Features

2.2.7 Balance Adjust

A flat balance adjustment is available in each WindowLite PLUS. This is useful when the unit is used with other equipment that is perceived to be reading slightly higher or lower than the WindowLite PLUS. This adjustment can be from -5.0 dB through +5.0 dB in 0.1 dB steps.

Please use this function with care! Each WindowLite PLUS is carefully calibrated in the factory to provide an instrument that is highly accurate over the operating temperature range. Balance Adjust should only be used to equalize multiple WindowLite PLUS reading differences only.

This scenario shows how to increase or decrease balance adjustment.

SoftKey Menu	Press Key	Results						
<table border="1"> <tr><td>TUNE</td><td>TAGS</td><td>ZOOM</td></tr> <tr><td>FUNCT</td><td>MORE</td><td>CURSOR</td></tr> </table>	TUNE	TAGS	ZOOM	FUNCT	MORE	CURSOR	ON or EXIT	Main Menu is displayed.
TUNE	TAGS	ZOOM						
FUNCT	MORE	CURSOR						
<table border="1"> <tr><td>TUNE</td><td>TAGS</td><td>ZOOM</td></tr> <tr><td>FUNCT</td><td>MORE</td><td>CURSOR</td></tr> </table>	TUNE	TAGS	ZOOM	FUNCT	MORE	CURSOR	F5	
TUNE	TAGS	ZOOM						
FUNCT	MORE	CURSOR						
<table border="1"> <tr><td>AUDIO</td><td>10 dB</td><td>MEMORY</td></tr> <tr><td>GROUP</td><td>SETUP</td><td>PREV</td></tr> </table>	AUDIO	10 dB	MEMORY	GROUP	SETUP	PREV	F5	
AUDIO	10 dB	MEMORY						
GROUP	SETUP	PREV						
<table border="1"> <tr><td>TP ADJ</td><td>STARTUP</td><td>TIMESSET</td></tr> <tr><td>dBμV</td><td>BALANCE</td><td>PREV</td></tr> </table>	TP ADJ	STARTUP	TIMESSET	dB μ V	BALANCE	PREV	F5	
TP ADJ	STARTUP	TIMESSET						
dB μ V	BALANCE	PREV						
<table border="1"> <tr><td>BAL+</td><td></td><td></td></tr> <tr><td>BAL-</td><td></td><td>PREV</td></tr> </table>	BAL+			BAL-		PREV	F1	Balance value is increased.
BAL+								
BAL-		PREV						
<table border="1"> <tr><td>BAL+</td><td></td><td></td></tr> <tr><td>BAL-</td><td></td><td>PREV</td></tr> </table>	BAL+			BAL-		PREV	F4	Balance value is decreased.
BAL+								
BAL-		PREV						
<table border="1"> <tr><td>BAL+</td><td></td><td></td></tr> <tr><td>BAL-</td><td></td><td>PREV</td></tr> </table>	BAL+			BAL-		PREV	F6	
BAL+								
BAL-		PREV						
<table border="1"> <tr><td>TP ADJ</td><td>STARTUP</td><td>TIMESSET</td></tr> <tr><td>dBμV</td><td>BALANCE</td><td>PREV</td></tr> </table>	TP ADJ	STARTUP	TIMESSET	dB μ V	BALANCE	PREV	F6	
TP ADJ	STARTUP	TIMESSET						
dB μ V	BALANCE	PREV						
<table border="1"> <tr><td>AUDIO</td><td>10 dB</td><td>MEMORY</td></tr> <tr><td>GROUP</td><td>SETUP</td><td>PREV</td></tr> </table>	AUDIO	10 dB	MEMORY	GROUP	SETUP	PREV	F6	
AUDIO	10 dB	MEMORY						
GROUP	SETUP	PREV						
<table border="1"> <tr><td>TUNE</td><td>TAGS</td><td>ZOOM</td></tr> <tr><td>FUNCT</td><td>MORE</td><td>CURSOR</td></tr> </table>	TUNE	TAGS	ZOOM	FUNCT	MORE	CURSOR		Main Menu is displayed.
TUNE	TAGS	ZOOM						
FUNCT	MORE	CURSOR						
The Unit to Unit Balance is a STARTUP definable parameter.								

Figure 13 - Balance Adjust Steps

WindowLite PLUS User's Guide

Section 2 - Operational Features

2.2.8 Units of Measure Toggle

The WindowLite PLUS can be configured to display its absolute measurement values in either dBmV (1.0 millivolt reference) or dB μ V (1.0 microvolt reference) units.

This scenario illustrates the procedure reset (toggle) display units.

SoftKey Menu	Press Key	Results						
<table border="1"><tr><td>TUNE</td><td>TAGS</td><td>ZOOM</td></tr><tr><td>FUNCT</td><td>MORE</td><td>CURSOR</td></tr></table>	TUNE	TAGS	ZOOM	FUNCT	MORE	CURSOR	ON or EXIT	Main Menu is displayed.
TUNE	TAGS	ZOOM						
FUNCT	MORE	CURSOR						
<table border="1"><tr><td>TUNE</td><td>TAGS</td><td>ZOOM</td></tr><tr><td>FUNCT</td><td>MORE</td><td>CURSOR</td></tr></table>	TUNE	TAGS	ZOOM	FUNCT	MORE	CURSOR	F5	
TUNE	TAGS	ZOOM						
FUNCT	MORE	CURSOR						
<table border="1"><tr><td>AUDIO</td><td>10 dB</td><td>MEMORY</td></tr><tr><td>GROUP</td><td>SETUP</td><td>PREV</td></tr></table>	AUDIO	10 dB	MEMORY	GROUP	SETUP	PREV	F5	dBmV / dB μ V units are toggled.
AUDIO	10 dB	MEMORY						
GROUP	SETUP	PREV						
<table border="1"><tr><td>TP ADJ</td><td>STARTUP</td><td>TIMESET</td></tr><tr><td>dBμV</td><td>BALANCE</td><td>PREV</td></tr></table>	TP ADJ	STARTUP	TIMESET	dBμV	BALANCE	PREV	F4	
TP ADJ	STARTUP	TIMESET						
dBμV	BALANCE	PREV						

Units dBmV / dB μ V is a STARTUP definable parameter.

Figure 14 - Units of Measure Toggle Steps

WindowLite PLUS User's Guide

Section 2 - Operational Features

2.2.9 Date/Time Reset

The WindowLite PLUS maintains a time-of-day clock along with the date. Both time and date are reset using this function. Time is entered and displayed in military style; that is, hours of the day start at 00 and run through 23. PM hours are 13 through 23. Date can be entered and displayed in either MM/DD/YY or DD/MM/YY format. The format is selectable using Date Format Select in Section 2.2.11, on page 22.

This scenario illustrates the procedure for resetting date and time.

SoftKey Menu	Press Key	Results						
<table border="1"> <tr> <td>TUNE</td> <td>TAGS</td> <td>ZOOM</td> </tr> <tr> <td>FUNCT</td> <td>MORE</td> <td>CURSOR</td> </tr> </table>	TUNE	TAGS	ZOOM	FUNCT	MORE	CURSOR	ON or EXIT	Main Menu is displayed.
TUNE	TAGS	ZOOM						
FUNCT	MORE	CURSOR						
<table border="1"> <tr> <td>TUNE</td> <td>TAGS</td> <td>ZOOM</td> </tr> <tr> <td>FUNCT</td> <td>MORE</td> <td>CURSOR</td> </tr> </table>	TUNE	TAGS	ZOOM	FUNCT	MORE	CURSOR	F5	
TUNE	TAGS	ZOOM						
FUNCT	MORE	CURSOR						
<table border="1"> <tr> <td>AUDIO</td> <td>10dB</td> <td>MEMORY</td> </tr> <tr> <td>GROUP</td> <td>SETUP</td> <td>PREV</td> </tr> </table>	AUDIO	10dB	MEMORY	GROUP	SETUP	PREV	F5	
AUDIO	10dB	MEMORY						
GROUP	SETUP	PREV						
<table border="1"> <tr> <td>TP ADJ</td> <td>STARTUP</td> <td>TIMESET</td> </tr> <tr> <td>dBμV</td> <td>BALANCE</td> <td>PREV</td> </tr> </table>	TP ADJ	STARTUP	TIMESET	dB μ V	BALANCE	PREV	F3	
TP ADJ	STARTUP	TIMESET						
dB μ V	BALANCE	PREV						
<table border="1"> <tr> <td>SHUT DN</td> <td>DD/MM</td> <td>CLOCK</td> </tr> <tr> <td></td> <td></td> <td>PREV</td> </tr> </table>	SHUT DN	DD/MM	CLOCK			PREV	F3	The current MONTH MM displays on the input line. Use the numeric keys and ENTER to set the appropriate month (01-12).
SHUT DN	DD/MM	CLOCK						
		PREV						
<table border="1"> <tr> <td></td> <td></td> <td></td> </tr> <tr> <td></td> <td>CANCEL</td> <td>PREV</td> </tr> </table>					CANCEL	PREV	NUM Keys and ENTER	The current DAY DD displays on the input line. Use the numeric keys and ENTER to set the appropriate day (01-31).
	CANCEL	PREV						
<table border="1"> <tr> <td></td> <td></td> <td></td> </tr> <tr> <td></td> <td>CANCEL</td> <td>PREV</td> </tr> </table>					CANCEL	PREV	NUM Keys and ENTER	The unit displays YEAR YY on the input line. YY is the current year number. Use the numeric keys and ENTER to set the appropriate year.
	CANCEL	PREV						
<table border="1"> <tr> <td></td> <td></td> <td></td> </tr> <tr> <td></td> <td>CANCEL</td> <td>PREV</td> </tr> </table>					CANCEL	PREV	NUM Keys and ENTER	The unit displays TIME HHMM on the input line. HHMM is the current time. Use the numeric keys and ENTER to set the appropriate time.
	CANCEL	PREV						
<table border="1"> <tr> <td>SHUT DN</td> <td>DD/MM</td> <td>CLOCK</td> </tr> <tr> <td></td> <td></td> <td>PREV</td> </tr> </table>	SHUT DN	DD/MM	CLOCK			PREV	F6, F6, F6 or EXIT	
SHUT DN	DD/MM	CLOCK						
		PREV						
<table border="1"> <tr> <td>TUNE</td> <td>TAGS</td> <td>ZOOM</td> </tr> <tr> <td>FUNCT</td> <td>MORE</td> <td>CURSOR</td> </tr> </table>	TUNE	TAGS	ZOOM	FUNCT	MORE	CURSOR		Main Menu is displayed.
TUNE	TAGS	ZOOM						
FUNCT	MORE	CURSOR						

Note that the Date and Time are resetable in the ATIS menu also.

Figure 15 - Date/Time Reset Steps

WindowLite PLUS User's Guide

Section 2 - Operational Features

2.2.10 Time Display

The WindowLite PLUS maintains a time-of-day clock along with the date. Time is displayed using this function.

This scenario illustrates the procedure for displaying time.

SoftKey Menu	Press Key	Results						
<table border="1"><tr><td>TUNE</td><td>TAGS</td><td>ZOOM</td></tr><tr><td>FUNCT</td><td>MORE</td><td>CURSOR</td></tr></table>	TUNE	TAGS	ZOOM	FUNCT	MORE	CURSOR	ON or EXIT	Main Menu is displayed.
TUNE	TAGS	ZOOM						
FUNCT	MORE	CURSOR						
<table border="1"><tr><td>TUNE</td><td>TAGS</td><td>ZOOM</td></tr><tr><td>FUNCT</td><td>MORE</td><td>CURSOR</td></tr></table>	TUNE	TAGS	ZOOM	FUNCT	MORE	CURSOR	F4	
TUNE	TAGS	ZOOM						
FUNCT	MORE	CURSOR						
<table border="1"><tr><td>CONTR+</td><td>TIME</td><td>TESTS</td></tr><tr><td>CONTR-</td><td>SOUND</td><td>PREV</td></tr></table>	CONTR+	TIME	TESTS	CONTR-	SOUND	PREV	F2	The output line displays MM/DD/YY HHMM.
CONTR+	TIME	TESTS						
CONTR-	SOUND	PREV						
<table border="1"><tr><td>CONTR+</td><td>TIME</td><td>TESTS</td></tr><tr><td>CONTR-</td><td>SOUND</td><td>PREV</td></tr></table>	CONTR+	TIME	TESTS	CONTR-	SOUND	PREV	F6 or EXIT	
CONTR+	TIME	TESTS						
CONTR-	SOUND	PREV						
<table border="1"><tr><td>TUNE</td><td>TAGS</td><td>ZOOM</td></tr><tr><td>FUNCT</td><td>MORE</td><td>CURSOR</td></tr></table>	TUNE	TAGS	ZOOM	FUNCT	MORE	CURSOR		Main Menu is displayed.
TUNE	TAGS	ZOOM						
FUNCT	MORE	CURSOR						

Figure 16 - Time Display Steps

WindowLite PLUS User's Guide

Section 2 - Operational Features

2.2.11 Date Format Select

The WindowLite PLUS maintains the date along with a time-of-day clock. Date can be entered and displayed in either MM/DD/YY or DD/MM/YY format. This function is a toggle used to make the selection.

This scenario illustrates the procedure for selecting date format.

<i>SoftKey Menu</i>	<i>Press Key</i>	<i>Results</i>						
<table border="1"> <tr> <td>TUNE</td> <td>TAGS</td> <td>ZOOM</td> </tr> <tr> <td>FUNCT</td> <td>MORE</td> <td>CURSOR</td> </tr> </table>	TUNE	TAGS	ZOOM	FUNCT	MORE	CURSOR	ON or EXIT	Main Menu is displayed.
TUNE	TAGS	ZOOM						
FUNCT	MORE	CURSOR						
<table border="1"> <tr> <td>TUNE</td> <td>TAGS</td> <td>ZOOM</td> </tr> <tr> <td>FUNCT</td> <td>MORE</td> <td>CURSOR</td> </tr> </table>	TUNE	TAGS	ZOOM	FUNCT	MORE	CURSOR	F5	
TUNE	TAGS	ZOOM						
FUNCT	MORE	CURSOR						
<table border="1"> <tr> <td>AUDIO</td> <td>10 dB</td> <td>MEMORY</td> </tr> <tr> <td>GROUP</td> <td>SETUP</td> <td>PREV</td> </tr> </table>	AUDIO	10 dB	MEMORY	GROUP	SETUP	PREV	F5	
AUDIO	10 dB	MEMORY						
GROUP	SETUP	PREV						
<table border="1"> <tr> <td>TP ADJ</td> <td>STARTUP</td> <td>TIMESET</td> </tr> <tr> <td>dBμV</td> <td>BALANCE</td> <td>PREV</td> </tr> </table>	TP ADJ	STARTUP	TIMESET	dB μ V	BALANCE	PREV	F3	
TP ADJ	STARTUP	TIMESET						
dB μ V	BALANCE	PREV						
<table border="1"> <tr> <td>SHUT DN</td> <td>MM/DD</td> <td>CLOCK</td> </tr> <tr> <td></td> <td></td> <td>PREV</td> </tr> </table>	SHUT DN	MM/DD	CLOCK			PREV	F2	Depressing F2 toggles between domestic (MM/DD) and European (DD/MM) date formats.
SHUT DN	MM/DD	CLOCK						
		PREV						
<table border="1"> <tr> <td>SHUT DN</td> <td>MM/DD</td> <td>CLOCK</td> </tr> <tr> <td></td> <td></td> <td>PREV</td> </tr> </table>	SHUT DN	MM/DD	CLOCK			PREV	F6, F6, F6 or EXIT	
SHUT DN	MM/DD	CLOCK						
		PREV						
<table border="1"> <tr> <td>TUNE</td> <td>TAGS</td> <td>ZOOM</td> </tr> <tr> <td>FUNCT</td> <td>MORE</td> <td>CURSOR</td> </tr> </table>	TUNE	TAGS	ZOOM	FUNCT	MORE	CURSOR		Main Menu is displayed.
TUNE	TAGS	ZOOM						
FUNCT	MORE	CURSOR						
Date Format is a STARTUP definable parameter.								

Figure 17 - Date Format Select Steps

WindowLite PLUS User's Guide

Section 3 - Using the WindowLite PLUS

3 Using the WindowLite PLUS

This section is divided into the following subsections. Within each subsection are appropriate scenarios designed to assist you in getting the most out of your WindowLite PLUS.

Topic	Description	Sub Section	Page
Controlling the unit	All about the numerous operational controls in the unit.	3.1	23
Groups	How Groups are used	3.2	28
Cursor Operation	How to use the Horizontal and Vertical Cursors.	3.3	36
Tuning to a channel	How to select a particular channel for observation.	3.4	38
Selecting Operational Mode	How to control the basic sweep and display characteristics... i.e. personality.	3.5	40
Making Measurements	The most important functions... Making readings	3.6	47
Using the Memory	How to store data to and recall data from the memory bins.	3.7	57

Table 5 - Topics

3.1 Controlling the Unit

The WindowLite PLUS has several toggles that are available and useful during regular operation of the unit. Two of these toggles are shown in the table below.

Function	Sub Section	Page #
Audio/Video Carrier Display Toggle	3.1.1	24
Display Range (10dB/30dB) Toggle	3.1.2	25
Listening to Channel Audio	3.1.3	26
Channel Audio Loudness	3.1.4	27

Table 6 - Controlling the Unit

WindowLite PLUS User's Guide

Section 3 - Using the WindowLite PLUS

3.1.1 Audio/Video Carrier Display Toggle

The Audio/Video carrier Display Toggle controls the display of carriers in Sweep and Tags mode. Normal startup displays video carriers. Selecting the Audio position causes the Audio carriers to be displayed.

Note that each channel in a Group can set to be **TV**, **FM**, or **DATA**. Channels marked as **FM** or **DATA** are only seen in a sweep mode when the unit is in the Audio sweep mode.

Note that the SoftKey toggles inversely with the carrier currently active. That is, when video is displayed, AUDIO appears in the SoftKey menu. Conversely, when audio is displayed, VIDEO appears in the SoftKey menu.

The scenario to switch between video and audio carrier is as follows:

SoftKey Menu	Press Key	Results						
<table border="1"><tr><td>TUNE</td><td>TAGS</td><td>ZOOM</td></tr><tr><td>FUNCT</td><td>MORE</td><td>CURSOR</td></tr></table>	TUNE	TAGS	ZOOM	FUNCT	MORE	CURSOR	ON or EXIT	Main Menu is displayed.
TUNE	TAGS	ZOOM						
FUNCT	MORE	CURSOR						
<table border="1"><tr><td>TUNE</td><td>TAGS</td><td>ZOOM</td></tr><tr><td>FUNCT</td><td>MORE</td><td>CURSOR</td></tr></table>	TUNE	TAGS	ZOOM	FUNCT	MORE	CURSOR	F5	
TUNE	TAGS	ZOOM						
FUNCT	MORE	CURSOR						
<table border="1"><tr><td>AUDIO</td><td>10 dB</td><td>MEMORY</td></tr><tr><td>GROUP</td><td>SETUP</td><td>PREV</td></tr></table>	AUDIO	10 dB	MEMORY	GROUP	SETUP	PREV	F1	Video / Audio display is toggled.
AUDIO	10 dB	MEMORY						
GROUP	SETUP	PREV						
<table border="1"><tr><td>VIDEO</td><td>10 dB</td><td>MEMORY</td></tr><tr><td>GROUP</td><td>SETUP</td><td>PREV</td></tr></table>	VIDEO	10 dB	MEMORY	GROUP	SETUP	PREV	F6	
VIDEO	10 dB	MEMORY						
GROUP	SETUP	PREV						
<table border="1"><tr><td>TUNE</td><td>TAGS</td><td>ZOOM</td></tr><tr><td>FUNCT</td><td>MORE</td><td>CURSOR</td></tr></table>	TUNE	TAGS	ZOOM	FUNCT	MORE	CURSOR		Main Menu is displayed.
TUNE	TAGS	ZOOM						
FUNCT	MORE	CURSOR						

Repeatedly pressing F1 causes AUDIO and VIDEO to alternate in the indicated SoftKey menu location. When Video carriers are tuned, AUDIO is displayed. When AUDIO carriers are tuned, VIDEO is displayed. AUDIO/VIDEO is a startup definable parameter. Note that PREV was used to return to the Main Menu, EXIT will return to the STARTUP mode setting.

Figure 18 - Audio/Video Carrier Display Toggle Steps

WindowLite PLUS User's Guide

Section 3 - Using the WindowLite PLUS

3.1.2 Display Range (10dB/30dB) Toggle

Another toggle available in the WindowLite PLUS controls the dynamic range of values displayed on the screen. The available ranges are 10dB full scale and 30dB full scale.

The scenario to switch between 10 and 30dB display range is as follows:

SoftKey Menu			Press Key	Results
TUNE	TAGS	ZOOM	ON or EXIT	Main Menu is displayed.
FUNCT	MORE	CURSOR		
TUNE	TAGS	ZOOM	F5	
FUNCT	MORE	CURSOR		
AUDIO	10 dB	MEMORY	F2	30dB / 10dB scale is toggled.
GROUP	SETUP	PREV		
AUDIO	30 dB	MEMORY	F2	10dB / 30dB scale is toggled.
GROUP	SETUP	PREV		

When the 10dB mode is active, 30dB is displayed in the SoftKey menu. When the 30dB mode is active, 10dB is displayed in the SoftKey menu.

Figure 19 - Display Range (10dB/30dB) Toggle Steps

WindowLite PLUS User's Guide

Section 3 - Using the WindowLite PLUS

3.1.3 Listening to Channel Audio

The WindowLite PLUS allows you to listen to the audio on the channel of interest. If you are in Tune or Zoom modes, demodulated audio at the presently tuned frequency is heard. Thus to hear the actual audio in those modes, you must cursor to the actual audio frequency.

This scenario shows how to listen to channel audio:

SoftKey Menu	Press Key	Results						
<table border="1"><tr><td>TUNE</td><td>TAGS</td><td>ZOOM</td></tr><tr><td>FUNCT</td><td>MORE</td><td>CURSOR</td></tr></table>	TUNE	TAGS	ZOOM	FUNCT	MORE	CURSOR	ON or EXIT	Main Menu is displayed.
TUNE	TAGS	ZOOM						
FUNCT	MORE	CURSOR						
<table border="1"><tr><td>TUNE</td><td>TAGS</td><td>ZOOM</td></tr><tr><td>FUNCT</td><td>MORE</td><td>CURSOR</td></tr></table>	TUNE	TAGS	ZOOM	FUNCT	MORE	CURSOR	F4	
TUNE	TAGS	ZOOM						
FUNCT	MORE	CURSOR						
<table border="1"><tr><td>CONTR+</td><td>TIME</td><td>TESTS</td></tr><tr><td>CONTR-</td><td>SOUND</td><td>PREV</td></tr></table>	CONTR+	TIME	TESTS	CONTR-	SOUND	PREV	F5	Audio turns on.
CONTR+	TIME	TESTS						
CONTR-	SOUND	PREV						
<table border="1"><tr><td>KEY BP+</td><td>LOUD+</td><td></td></tr><tr><td>KEY BP-</td><td>LOUD-</td><td>PREV</td></tr></table>	KEY BP+	LOUD+		KEY BP-	LOUD-	PREV	F6	
KEY BP+	LOUD+							
KEY BP-	LOUD-	PREV						
<table border="1"><tr><td>CONTR+</td><td>TIME</td><td>TESTS</td></tr><tr><td>CONTR-</td><td>SOUND</td><td>PREV</td></tr></table>	CONTR+	TIME	TESTS	CONTR-	SOUND	PREV	F6	
CONTR+	TIME	TESTS						
CONTR-	SOUND	PREV						
<table border="1"><tr><td>TUNE</td><td>TAGS</td><td>ZOOM</td></tr><tr><td>FUNCT</td><td>MORE</td><td>CURSOR</td></tr></table>	TUNE	TAGS	ZOOM	FUNCT	MORE	CURSOR		Main Menu is displayed.
TUNE	TAGS	ZOOM						
FUNCT	MORE	CURSOR						

Figure 20 - Listening to Channel Audio Steps

Note that while you are listening to the channel audio, you can use any of the three channel tuning methods (see Section 3.4, on page 38) to change to another channel.

WindowLite PLUS User's Guide

Section 3 - Using the WindowLite PLUS

3.1.4 Channel Audio Loudness

With the WindowLite PLUS, you can listen to the audio of the current channel of interest. For various reasons, you may wish to adjust the volume of the Channel Audio.

The channel audio loudness has a range of 0 to 16. When the unit's sound function is selected (see Section 3.1.3, on page 26) the loudness is reset to level 1.

The scenario below shows how to adjust audio level.

SoftKey Menu	Press Key	Results						
<table border="1"> <tr><td>TUNE</td><td>TAGS</td><td>ZOOM</td></tr> <tr><td>FUNCT</td><td>MORE</td><td>CURSOR</td></tr> </table>	TUNE	TAGS	ZOOM	FUNCT	MORE	CURSOR	ON or EXIT	Main Menu is displayed.
TUNE	TAGS	ZOOM						
FUNCT	MORE	CURSOR						
<table border="1"> <tr><td>TUNE</td><td>TAGS</td><td>ZOOM</td></tr> <tr><td>FUNCT</td><td>MORE</td><td>CURSOR</td></tr> </table>	TUNE	TAGS	ZOOM	FUNCT	MORE	CURSOR	F4	
TUNE	TAGS	ZOOM						
FUNCT	MORE	CURSOR						
<table border="1"> <tr><td>CONTR+</td><td>TIME</td><td>TESTS</td></tr> <tr><td>CONTR-</td><td>SOUND</td><td>PREV</td></tr> </table>	CONTR+	TIME	TESTS	CONTR-	SOUND	PREV	F5	
CONTR+	TIME	TESTS						
CONTR-	SOUND	PREV						
<table border="1"> <tr><td>KEY BP+</td><td>LOUD+</td><td></td></tr> <tr><td>KEY BP-</td><td>LOUD-</td><td>PREV</td></tr> </table>	KEY BP+	LOUD+		KEY BP-	LOUD-	PREV	F2	Loudness Increases.
KEY BP+	LOUD+							
KEY BP-	LOUD-	PREV						
<table border="1"> <tr><td>KEY BP+</td><td>LOUD+</td><td></td></tr> <tr><td>KEY BP-</td><td>LOUD-</td><td>PREV</td></tr> </table>	KEY BP+	LOUD+		KEY BP-	LOUD-	PREV	F5	Loudness Decreases.
KEY BP+	LOUD+							
KEY BP-	LOUD-	PREV						
<table border="1"> <tr><td>KEY BP+</td><td>LOUD+</td><td></td></tr> <tr><td>KEY BP-</td><td>LOUD-</td><td>PREV</td></tr> </table>	KEY BP+	LOUD+		KEY BP-	LOUD-	PREV	F6	Audio turns off.
KEY BP+	LOUD+							
KEY BP-	LOUD-	PREV						
<table border="1"> <tr><td>CONTR+</td><td>TIME</td><td>TESTS</td></tr> <tr><td>CONTR-</td><td>SOUND</td><td>PREV</td></tr> </table>	CONTR+	TIME	TESTS	CONTR-	SOUND	PREV	F6	
CONTR+	TIME	TESTS						
CONTR-	SOUND	PREV						
<table border="1"> <tr><td>TUNE</td><td>TAGS</td><td>ZOOM</td></tr> <tr><td>FUNCT</td><td>MORE</td><td>CURSOR</td></tr> </table>	TUNE	TAGS	ZOOM	FUNCT	MORE	CURSOR		Main Menu is displayed.
TUNE	TAGS	ZOOM						
FUNCT	MORE	CURSOR						

Tuned channel audio loudness is increased and decreased a small portion with each keypress. Once the maximum or minimum level is reached, additional depresses are ignored. Note that pressing EXIT will reset the loudness to level 1.

Figure 21 - Channel Audio Loudness Steps

WindowLite PLUS User's Guide

Section 3 - Using the WindowLite PLUS

3.2 Groups

The WindowLite PLUS contains space for 6 Groups. Each Group can be personalized to meet the needs of the user and the cable system.

Topic	Sub Section	Page #
Selecting the Active Group	3.2.1	29
Initializing a Group With a New Format	3.2.2	30
Naming a Group	3.2.3	31
Delete a Channel Within a Group	3.2.4	32
Add a Channel Within a Group	3.2.5	33
Change a Channel's Frequency, Name or Type	3.2.6	34
Changing the Tags Within a Group	3.2.7	35

Table 7 - Groups

A table containing all of the personality items, their range, default values, etc., are located in Section 2.2.1 on page 12.

WindowLite PLUS User's Guide

Section 3 - Using the WindowLite PLUS

3.2.1 Selecting the Active Group

The WindowLite PLUS activates only a single Group at a time. From the factory, Group 1 is active. This Group selection function enables the user to choose any other Group for use.

The following scenario shows how to select a group.

SoftKey Menu	Press Key	Results						
<table border="1"> <tr><td>TUNE</td><td>TAGS</td><td>ZOOM</td></tr> <tr><td>FUNCT</td><td>MORE</td><td>CURSOR</td></tr> </table>	TUNE	TAGS	ZOOM	FUNCT	MORE	CURSOR	ON or EXIT	Main Menu is displayed.
TUNE	TAGS	ZOOM						
FUNCT	MORE	CURSOR						
<table border="1"> <tr><td>TUNE</td><td>TAGS</td><td>ZOOM</td></tr> <tr><td>FUNCT</td><td>MORE</td><td>CURSOR</td></tr> </table>	TUNE	TAGS	ZOOM	FUNCT	MORE	CURSOR	F5	
TUNE	TAGS	ZOOM						
FUNCT	MORE	CURSOR						
<table border="1"> <tr><td>AUDIO</td><td>10 dB</td><td>MEMORY</td></tr> <tr><td>GROUP</td><td>SETUP</td><td>PREV</td></tr> </table>	AUDIO	10 dB	MEMORY	GROUP	SETUP	PREV	F4	
AUDIO	10 dB	MEMORY						
GROUP	SETUP	PREV						
<table border="1"> <tr><td>STD EIA</td><td>GROUP 2</td><td>GROUP 3</td></tr> <tr><td>DEFINE</td><td>MORE</td><td>PREV</td></tr> </table>	STD EIA	GROUP 2	GROUP 3	DEFINE	MORE	PREV	F1, F2, F3 or F5	Select from groups 1 - 3. MORE will display options for groups 4 - 6.
STD EIA	GROUP 2	GROUP 3						
DEFINE	MORE	PREV						
<table border="1"> <tr><td>TUNE</td><td>TAGS</td><td>ZOOM</td></tr> <tr><td>FUNCT</td><td>MORE</td><td>CURSOR</td></tr> </table>	TUNE	TAGS	ZOOM	FUNCT	MORE	CURSOR	EXIT	Main Menu is displayed.
TUNE	TAGS	ZOOM						
FUNCT	MORE	CURSOR						

F5 is used to set up for selection of groups 4 through 6. Group Select is a STARTUP definable parameter.

Figure 22 - Selecting the Active Group

WindowLite PLUS User's Guide

Section 3 - Using the WindowLite PLUS

3.2.2 Initializing a Group with a new Format

In order to personalize the WindowLite PLUS to meet your needs, you can change the Format of the channels in any Group. This capability allows you to select any of the Formats listed in Section 2.1.5, on page 10.

Note: Audio frequency offset from the video carrier is automatically assigned by the selected Format. Choosing an incorrect Format may result in inappropriate measurement values.

SoftKey Menu	Press Key	Results						
<table border="1"> <tr><td>TUNE</td><td>TAGS</td><td>ZOOM</td></tr> <tr><td>FUNCT</td><td>MORE</td><td>CURSOR</td></tr> </table>	TUNE	TAGS	ZOOM	FUNCT	MORE	CURSOR	ON or EXIT	Main Menu is displayed.
TUNE	TAGS	ZOOM						
FUNCT	MORE	CURSOR						
<table border="1"> <tr><td>TUNE</td><td>TAGS</td><td>ZOOM</td></tr> <tr><td>FUNCT</td><td>MORE</td><td>CURSOR</td></tr> </table>	TUNE	TAGS	ZOOM	FUNCT	MORE	CURSOR	F5	
TUNE	TAGS	ZOOM						
FUNCT	MORE	CURSOR						
<table border="1"> <tr><td>AUDIO</td><td>10 dB</td><td>MEMORY</td></tr> <tr><td>GROUP</td><td>SETUP</td><td>PREV</td></tr> </table>	AUDIO	10 dB	MEMORY	GROUP	SETUP	PREV	F4	
AUDIO	10 dB	MEMORY						
GROUP	SETUP	PREV						
<table border="1"> <tr><td>STD EIA</td><td>GROUP 2</td><td>GROUP 3</td></tr> <tr><td>DEFINE</td><td>MORE</td><td>PREV</td></tr> </table>	STD EIA	GROUP 2	GROUP 3	DEFINE	MORE	PREV	F1, F2, F3 or F5	Select the appropriate group.
STD EIA	GROUP 2	GROUP 3						
DEFINE	MORE	PREV						
<table border="1"> <tr><td>STD EIA</td><td>GROUP 2</td><td>GROUP 3</td></tr> <tr><td>DEFINE</td><td>MORE</td><td>PREV</td></tr> </table>	STD EIA	GROUP 2	GROUP 3	DEFINE	MORE	PREV	F4	
STD EIA	GROUP 2	GROUP 3						
DEFINE	MORE	PREV						
<table border="1"> <tr><td>FORMAT</td><td></td><td>CHANNEL</td></tr> <tr><td>NAME</td><td>CANCEL</td><td>PREV</td></tr> </table>	FORMAT		CHANNEL	NAME	CANCEL	PREV	F1	
FORMAT		CHANNEL						
NAME	CANCEL	PREV						
<table border="1"> <tr><td>STD EIA</td><td>HRC EIA</td><td>IRC EIA</td></tr> <tr><td></td><td>MORE</td><td>PREV</td></tr> </table>	STD EIA	HRC EIA	IRC EIA		MORE	PREV	F1, F2, F3 or F5	Select the appropriate format.
STD EIA	HRC EIA	IRC EIA						
	MORE	PREV						
<table border="1"> <tr><td>FORMAT</td><td></td><td>CHANNEL</td></tr> <tr><td>NAME</td><td>CANCEL</td><td>PREV</td></tr> </table>	FORMAT		CHANNEL	NAME	CANCEL	PREV	F6	Format is stored into the group.
FORMAT		CHANNEL						
NAME	CANCEL	PREV						
<table border="1"> <tr><td>STD EIA</td><td>GROUP 2</td><td>GROUP 3</td></tr> <tr><td>DEFINE</td><td>MORE</td><td>PREV</td></tr> </table>	STD EIA	GROUP 2	GROUP 3	DEFINE	MORE	PREV	F6	
STD EIA	GROUP 2	GROUP 3						
DEFINE	MORE	PREV						
<table border="1"> <tr><td>AUDIO</td><td>10 dB</td><td>MEMORY</td></tr> <tr><td>GROUP</td><td>SETUP</td><td>PREV</td></tr> </table>	AUDIO	10 dB	MEMORY	GROUP	SETUP	PREV	F6	
AUDIO	10 dB	MEMORY						
GROUP	SETUP	PREV						
<table border="1"> <tr><td>TUNE</td><td>TAGS</td><td>ZOOM</td></tr> <tr><td>FUNCT</td><td>MORE</td><td>CURSOR</td></tr> </table>	TUNE	TAGS	ZOOM	FUNCT	MORE	CURSOR		Main Menu is displayed.
TUNE	TAGS	ZOOM						
FUNCT	MORE	CURSOR						

Pressing EXIT will load the format into the selected group. On powerup the active group will revert to the startup group.

Figure 23 - Initializing a Group with a new Format Steps

WindowLite PLUS User's Guide

Section 3 - Using the WindowLite PLUS

3.2.3 Naming a Group

The name of each Group can be personalized to meet the user's needs. The maximum length of the name is 7 characters including any blanks or special characters.

The following scenario shows how to name a Group.

SoftKey Menu	Press Key	Results						
<table border="1"> <tr><td>TUNE</td><td>TAGS</td><td>ZOOM</td></tr> <tr><td>FUNCT</td><td>MORE</td><td>CURSOR</td></tr> </table>	TUNE	TAGS	ZOOM	FUNCT	MORE	CURSOR	ON or EXIT	Main Menu is displayed.
TUNE	TAGS	ZOOM						
FUNCT	MORE	CURSOR						
<table border="1"> <tr><td>TUNE</td><td>TAGS</td><td>ZOOM</td></tr> <tr><td>FUNCT</td><td>MORE</td><td>CURSOR</td></tr> </table>	TUNE	TAGS	ZOOM	FUNCT	MORE	CURSOR	F5	
TUNE	TAGS	ZOOM						
FUNCT	MORE	CURSOR						
<table border="1"> <tr><td>AUDIO</td><td>10 dB</td><td>MEMORY</td></tr> <tr><td>GROUP</td><td>SETUP</td><td>PREV</td></tr> </table>	AUDIO	10 dB	MEMORY	GROUP	SETUP	PREV	F4	
AUDIO	10 dB	MEMORY						
GROUP	SETUP	PREV						
<table border="1"> <tr><td>STD EIA</td><td>GROUP 2</td><td>GROUP 3</td></tr> <tr><td>DEFINE</td><td>MORE</td><td>PREV</td></tr> </table>	STD EIA	GROUP 2	GROUP 3	DEFINE	MORE	PREV	F1, F2, F3 or F5	Select group to name.
STD EIA	GROUP 2	GROUP 3						
DEFINE	MORE	PREV						
<table border="1"> <tr><td>STD EIA</td><td>GROUP 2</td><td>GROUP 3</td></tr> <tr><td>DEFINE</td><td>MORE</td><td>PREV</td></tr> </table>	STD EIA	GROUP 2	GROUP 3	DEFINE	MORE	PREV	F4	
STD EIA	GROUP 2	GROUP 3						
DEFINE	MORE	PREV						
<table border="1"> <tr><td>FORMAT</td><td></td><td>CHANNEL</td></tr> <tr><td>NAME</td><td>CANCEL</td><td>PREV</td></tr> </table>	FORMAT		CHANNEL	NAME	CANCEL	PREV	F4	
FORMAT		CHANNEL						
NAME	CANCEL	PREV						
<table border="1"> <tr><td>ABCDE</td><td>FGHIJ</td><td>KLMNO</td></tr> <tr><td>CANCEL</td><td>MORE</td><td>PREV</td></tr> </table>	ABCDE	FGHIJ	KLMNO	CANCEL	MORE	PREV	F1, F2, F3 or F5	Proceed to select the characters to form the name of the group. Press ENTER after the last character.
ABCDE	FGHIJ	KLMNO						
CANCEL	MORE	PREV						
<table border="1"> <tr><td>TUNE</td><td>TAGS</td><td>ZOOM</td></tr> <tr><td>FUNCT</td><td>MORE</td><td>CURSOR</td></tr> </table>	TUNE	TAGS	ZOOM	FUNCT	MORE	CURSOR	EXIT	Main Menu is displayed.
TUNE	TAGS	ZOOM						
FUNCT	MORE	CURSOR						
Pressing the Left Arrow key will delete the last character selected.								

Figure 24 - Naming a Group Steps

WindowLite PLUS User's Guide

Section 3 - Using the WindowLite PLUS

3.2.4 Delete a Channel within a Group

In order to further personalize your WindowLite PLUS, provision is made to delete one or more channels from a Group.

The following scenario shows how to delete a channel.

SoftKey Menu	Press Key	Results						
<table border="1"> <tr><td>TUNE</td><td>TAGS</td><td>ZOOM</td></tr> <tr><td>FUNCT</td><td>MORE</td><td>CURSOR</td></tr> </table>	TUNE	TAGS	ZOOM	FUNCT	MORE	CURSOR	ON or EXIT	Main Menu is displayed.
TUNE	TAGS	ZOOM						
FUNCT	MORE	CURSOR						
<table border="1"> <tr><td>TUNE</td><td>TAGS</td><td>ZOOM</td></tr> <tr><td>FUNCT</td><td>MORE</td><td>CURSOR</td></tr> </table>	TUNE	TAGS	ZOOM	FUNCT	MORE	CURSOR	F5	
TUNE	TAGS	ZOOM						
FUNCT	MORE	CURSOR						
<table border="1"> <tr><td>AUDIO</td><td>10 dB</td><td>MEMORY</td></tr> <tr><td>GROUP</td><td>MORE</td><td>PREV</td></tr> </table>	AUDIO	10 dB	MEMORY	GROUP	MORE	PREV	F4	
AUDIO	10 dB	MEMORY						
GROUP	MORE	PREV						
<table border="1"> <tr><td>STD EIA</td><td>GROUP 2</td><td>GROUP 3</td></tr> <tr><td>DEFINE</td><td>MORE</td><td>PREV</td></tr> </table>	STD EIA	GROUP 2	GROUP 3	DEFINE	MORE	PREV	F1, F2, F3 or F5	Select the appropriate group.
STD EIA	GROUP 2	GROUP 3						
DEFINE	MORE	PREV						
<table border="1"> <tr><td>STD EIA</td><td>GROUP 2</td><td>GROUP 3</td></tr> <tr><td>DEFINE</td><td>MORE</td><td>PREV</td></tr> </table>	STD EIA	GROUP 2	GROUP 3	DEFINE	MORE	PREV	F4	
STD EIA	GROUP 2	GROUP 3						
DEFINE	MORE	PREV						
<table border="1"> <tr><td>FORMAT</td><td></td><td>CHANNEL</td></tr> <tr><td>NAME</td><td>CANCEL</td><td>PREV</td></tr> </table>	FORMAT		CHANNEL	NAME	CANCEL	PREV	F3	
FORMAT		CHANNEL						
NAME	CANCEL	PREV						
<table border="1"> <tr><td>CHANGE</td><td></td><td>DELETE</td></tr> <tr><td>ADD</td><td>TAG</td><td>PREV</td></tr> </table>	CHANGE		DELETE	ADD	TAG	PREV	NUM Keys	Use the numeric keys or arrow keys to select the appropriate channel to delete.
CHANGE		DELETE						
ADD	TAG	PREV						
<table border="1"> <tr><td>CHANGE</td><td></td><td>DELETE</td></tr> <tr><td>ADD</td><td>TAG</td><td>PREV</td></tr> </table>	CHANGE		DELETE	ADD	TAG	PREV	F3	
CHANGE		DELETE						
ADD	TAG	PREV						
<table border="1"> <tr><td>TUNE</td><td>TAGS</td><td>ZOOM</td></tr> <tr><td>FUNCT</td><td>MORE</td><td>CURSOR</td></tr> </table>	TUNE	TAGS	ZOOM	FUNCT	MORE	CURSOR	EXIT	Main Menu is displayed.
TUNE	TAGS	ZOOM						
FUNCT	MORE	CURSOR						

To delete multiple adjacent channels, locate the highest channel to be removed. Then press DELETE multiple times until all unwanted channels are removed. (Once a channel is deleted, the next lower frequency is displayed. If there is no lower channel, then the next higher will be displayed.)

Figure 25 - Delete a Channel within a Group Steps

The width of the sweep display is optimized for the number of channels in the selected group. Groups containing at or near the following number of channels are displayed at full width: 128, 64, 43, 32, 16, 10, or 8. The minimum group size is 5 channels.

WindowLite PLUS User's Guide

Section 3 - Using the WindowLite PLUS

3.2.5 Add a Channel within a Group

During personalization of the WindowLite PLUS, it may be necessary to add one or more channels to a Group. Remember that the maximum size of a Group is 128 channels. (TV, FM and Data all count as channels.) If the Group is currently full and you need to add a channel, you'll have to delete one to make room for the addition. For information on deleting a channel look at Section 3.2.4 on page 32.

The following scenario shows how to add a channel.

SoftKey Menu	Press Key	Results						
<table border="1"> <tr><td>TUNE</td><td>TAGS</td><td>ZOOM</td></tr> <tr><td>FUNCT</td><td>MORE</td><td>CURSOR</td></tr> </table>	TUNE	TAGS	ZOOM	FUNCT	MORE	CURSOR	ON or EXIT	Main Menu is displayed.
TUNE	TAGS	ZOOM						
FUNCT	MORE	CURSOR						
<table border="1"> <tr><td>TUNE</td><td>TAGS</td><td>ZOOM</td></tr> <tr><td>FUNCT</td><td>MORE</td><td>CURSOR</td></tr> </table>	TUNE	TAGS	ZOOM	FUNCT	MORE	CURSOR	F5	
TUNE	TAGS	ZOOM						
FUNCT	MORE	CURSOR						
<table border="1"> <tr><td>AUDIO</td><td>10 dB</td><td>MEMORY</td></tr> <tr><td>GROUP</td><td>SETUP</td><td>PREV</td></tr> </table>	AUDIO	10 dB	MEMORY	GROUP	SETUP	PREV	F4	
AUDIO	10 dB	MEMORY						
GROUP	SETUP	PREV						
<table border="1"> <tr><td>STD EIA</td><td>GROUP 2</td><td>GROUP 3</td></tr> <tr><td>DEFINE</td><td>MORE</td><td>PREV</td></tr> </table>	STD EIA	GROUP 2	GROUP 3	DEFINE	MORE	PREV	F1, F2, F3 or F5	Select appropriate group. First 3 groups are shown. To select from groups 4 - 6, press MORE .
STD EIA	GROUP 2	GROUP 3						
DEFINE	MORE	PREV						
<table border="1"> <tr><td>STD EIA</td><td>GROUP 2</td><td>GROUP 3</td></tr> <tr><td>DEFINE</td><td>MORE</td><td>PREV</td></tr> </table>	STD EIA	GROUP 2	GROUP 3	DEFINE	MORE	PREV	F4	
STD EIA	GROUP 2	GROUP 3						
DEFINE	MORE	PREV						
<table border="1"> <tr><td>FORMAT</td><td></td><td>CHANNEL</td></tr> <tr><td>NAME</td><td>CANCEL</td><td>PREV</td></tr> </table>	FORMAT		CHANNEL	NAME	CANCEL	PREV	F3	
FORMAT		CHANNEL						
NAME	CANCEL	PREV						
<table border="1"> <tr><td>CHANGE</td><td></td><td>DELETE</td></tr> <tr><td>ADD</td><td>TAG</td><td>PREV</td></tr> </table>	CHANGE		DELETE	ADD	TAG	PREV	F4	Freq: _____ Enter video frequency for new channel. Press ENTER to proceed.
CHANGE		DELETE						
ADD	TAG	PREV						
<table border="1"> <tr><td>ABCDE</td><td>FGHIJ</td><td>KLMNO</td></tr> <tr><td>CANCEL</td><td>MORE</td><td>PREV</td></tr> </table>	ABCDE	FGHIJ	KLMNO	CANCEL	MORE	PREV	F1, F2, F3 or F5	Name: _____ Use the appropriate keys to select up to 4 characters for the name. Press ENTER after the last character.
ABCDE	FGHIJ	KLMNO						
CANCEL	MORE	PREV						
<table border="1"> <tr><td>TV</td><td>FM</td><td>DATA</td></tr> <tr><td></td><td></td><td></td></tr> </table>	TV	FM	DATA				F1, F2, or F3	Type: _____ Select the type of channel. Press ENTER to proceed.
TV	FM	DATA						
<table border="1"> <tr><td>TUNE</td><td>TAGS</td><td>ZOOM</td></tr> <tr><td>FUNCT</td><td>MORE</td><td>CURSOR</td></tr> </table>	TUNE	TAGS	ZOOM	FUNCT	MORE	CURSOR	EXIT	Press EXIT to store changes and display Main Menu.
TUNE	TAGS	ZOOM						
FUNCT	MORE	CURSOR						

Figure 26 - Add a Channel within a Group

Audio carriers are automatically included with TV channels based on the *audio offset* for the format of the group. For information on formats, see Section 4.1 Format Sets, page 60. FM and data carriers are single frequency channels and do not have associated audio carriers.

FM and **DATA** channels are displayed and available for measurement only in the audio carrier mode. See Section 3.6.3 Audio Carrier Measurement, page 50.

WindowLite PLUS User's Guide

Section 3 - Using the WindowLite PLUS

3.2.6 Change Channel Frequency, Name, Type

To further personalize your WindowLite PLUS, you are given the opportunity to change the frequency, name, or type of any channel in any Group.

The following scenario shows how to change frequency, name, or type:

SoftKey Menu	Press Key	Results						
<table border="1"> <tr> <td>TUNE</td> <td>TAGS</td> <td>ZOOM</td> </tr> <tr> <td>FUNCT</td> <td>MORE</td> <td>CURSOR</td> </tr> </table>	TUNE	TAGS	ZOOM	FUNCT	MORE	CURSOR	ON or EXIT	Main Menu is displayed.
TUNE	TAGS	ZOOM						
FUNCT	MORE	CURSOR						
<table border="1"> <tr> <td>TUNE</td> <td>TAGS</td> <td>ZOOM</td> </tr> <tr> <td>FUNCT</td> <td>MORE</td> <td>CURSOR</td> </tr> </table>	TUNE	TAGS	ZOOM	FUNCT	MORE	CURSOR	F5	
TUNE	TAGS	ZOOM						
FUNCT	MORE	CURSOR						
<table border="1"> <tr> <td>AUDIO</td> <td>10 dB</td> <td>MEMORY</td> </tr> <tr> <td>GROUP</td> <td>SETUP</td> <td>PREV</td> </tr> </table>	AUDIO	10 dB	MEMORY	GROUP	SETUP	PREV	F4	
AUDIO	10 dB	MEMORY						
GROUP	SETUP	PREV						
<table border="1"> <tr> <td>STD EIA</td> <td>GROUP 2</td> <td>GROUP 3</td> </tr> <tr> <td>DEFINE</td> <td>MORE</td> <td>PREV</td> </tr> </table>	STD EIA	GROUP 2	GROUP 3	DEFINE	MORE	PREV	F1, F2, F3 or F5	Select appropriate group. First 3 groups are shown. To select from groups 4 - 6, press MORE .
STD EIA	GROUP 2	GROUP 3						
DEFINE	MORE	PREV						
<table border="1"> <tr> <td>STD EIA</td> <td>GROUP 2</td> <td>GROUP 3</td> </tr> <tr> <td>DEFINE</td> <td>MORE</td> <td>PREV</td> </tr> </table>	STD EIA	GROUP 2	GROUP 3	DEFINE	MORE	PREV	F4	
STD EIA	GROUP 2	GROUP 3						
DEFINE	MORE	PREV						
<table border="1"> <tr> <td>FORMAT</td> <td></td> <td>CHANNEL</td> </tr> <tr> <td>NAME</td> <td>CANCEL</td> <td>PREV</td> </tr> </table>	FORMAT		CHANNEL	NAME	CANCEL	PREV	F3	
FORMAT		CHANNEL						
NAME	CANCEL	PREV						
<table border="1"> <tr> <td>CHANGE</td> <td></td> <td>DELETE</td> </tr> <tr> <td>ADD</td> <td>TAG</td> <td>PREV</td> </tr> </table>	CHANGE		DELETE	ADD	TAG	PREV	NUM Keys	Use the numeric keys and ENTER or the arrow keys to select the channel to change.
CHANGE		DELETE						
ADD	TAG	PREV						
<table border="1"> <tr> <td>CHANGE</td> <td></td> <td>DELETE</td> </tr> <tr> <td>ADD</td> <td>TAG</td> <td>PREV</td> </tr> </table>	CHANGE		DELETE	ADD	TAG	PREV	F1	Freq: _____ Enter video frequency for new channel. Press ENTER to proceed.
CHANGE		DELETE						
ADD	TAG	PREV						
<table border="1"> <tr> <td>ABCDE</td> <td>FGHIJ</td> <td>KLMNO</td> </tr> <tr> <td>CANCEL</td> <td>MORE</td> <td>PREV</td> </tr> </table>	ABCDE	FGHIJ	KLMNO	CANCEL	MORE	PREV	F1, F2, F3 or F5	Name: _____ Use the appropriate keys to select up to 4 characters for the name. Press ENTER after the last character.
ABCDE	FGHIJ	KLMNO						
CANCEL	MORE	PREV						
<table border="1"> <tr> <td>TV</td> <td>FM</td> <td>DATA</td> </tr> <tr> <td></td> <td></td> <td></td> </tr> </table>	TV	FM	DATA				F1, F2, F3	Type: _____ Select the type of channel. Press ENTER to proceed.
TV	FM	DATA						
<table border="1"> <tr> <td>TUNE</td> <td>TAGS</td> <td>ZOOM</td> </tr> <tr> <td>FUNCT</td> <td>MORE</td> <td>CURSOR</td> </tr> </table>	TUNE	TAGS	ZOOM	FUNCT	MORE	CURSOR	EXIT	Press EXIT to store changes and display Main Menu.
TUNE	TAGS	ZOOM						
FUNCT	MORE	CURSOR						

Figure 27 - Change Channel Frequency, Name, Type Steps

Audio carriers are automatically included with TV channels based on the *audio offset* for the format of the group. For information on formats, see Section 4.1 Format Sets, page 60. FM and data carriers are single frequency channels and do not have associated audio carriers.

FM and **DATA** channels are displayed and available for measurement only in the audio carrier mode. See Section 3.6.3 Audio Carrier Measurement, page 50.

WindowLite PLUS User's Guide

Section 3 - Using the WindowLite PLUS

3.2.7 Changing the Tags within a Group

To meet your needs, channels that are marked as tags in each Group can be changed. There are always 5 tag channels present in each group.

The following scenario takes you through this procedure.

SoftKey Menu	Press Key	Results						
<table border="1"> <tr><td>TUNE</td><td>TAGS</td><td>ZOOM</td></tr> <tr><td>FUNCT</td><td>MORE</td><td>CURSOR</td></tr> </table>	TUNE	TAGS	ZOOM	FUNCT	MORE	CURSOR	ON or EXIT	Main Menu is displayed.
TUNE	TAGS	ZOOM						
FUNCT	MORE	CURSOR						
<table border="1"> <tr><td>TUNE</td><td>TAGS</td><td>ZOOM</td></tr> <tr><td>FUNCT</td><td>MORE</td><td>CURSOR</td></tr> </table>	TUNE	TAGS	ZOOM	FUNCT	MORE	CURSOR	F5	
TUNE	TAGS	ZOOM						
FUNCT	MORE	CURSOR						
<table border="1"> <tr><td>AUDIO</td><td>10 dB</td><td>MEMORY</td></tr> <tr><td>GROUP</td><td>SETUP</td><td>PREV</td></tr> </table>	AUDIO	10 dB	MEMORY	GROUP	SETUP	PREV	F4	
AUDIO	10 dB	MEMORY						
GROUP	SETUP	PREV						
<table border="1"> <tr><td>STD EIA</td><td>GROUP 2</td><td>GROUP 3</td></tr> <tr><td>DEFINE</td><td>MORE</td><td>PREV</td></tr> </table>	STD EIA	GROUP 2	GROUP 3	DEFINE	MORE	PREV	F1, F2, F3 or F5	Select appropriate group. First 3 groups are shown. To select from groups 4 - 6, press MORE .
STD EIA	GROUP 2	GROUP 3						
DEFINE	MORE	PREV						
<table border="1"> <tr><td>STD EIA</td><td>GROUP 2</td><td>GROUP 3</td></tr> <tr><td>DEFINE</td><td>MORE</td><td>PREV</td></tr> </table>	STD EIA	GROUP 2	GROUP 3	DEFINE	MORE	PREV	F4	
STD EIA	GROUP 2	GROUP 3						
DEFINE	MORE	PREV						
<table border="1"> <tr><td>FORMAT</td><td></td><td>CHANNEL</td></tr> <tr><td>NAME</td><td>CANCEL</td><td>PREV</td></tr> </table>	FORMAT		CHANNEL	NAME	CANCEL	PREV	F3	
FORMAT		CHANNEL						
NAME	CANCEL	PREV						
<table border="1"> <tr><td>CHANGE</td><td></td><td>DELETE</td></tr> <tr><td>ADD</td><td>TAG</td><td>PREV</td></tr> </table>	CHANGE		DELETE	ADD	TAG	PREV	F5	
CHANGE		DELETE						
ADD	TAG	PREV						
<table border="1"> <tr><td>CHANGE</td><td></td><td>DELETE</td></tr> <tr><td>ADD</td><td>TAG</td><td>PREV</td></tr> </table>	CHANGE		DELETE	ADD	TAG	PREV	NUM Keys or Arrow Keys	Move the cursor to the replacement TAG channel by using either the arrow keys or the numeric keypad.
CHANGE		DELETE						
ADD	TAG	PREV						
<table border="1"> <tr><td>TAG 1</td><td>TAG 2</td><td>TAG 3</td></tr> <tr><td>TAG 4</td><td>TAG 5</td><td>PREV</td></tr> </table>	TAG 1	TAG 2	TAG 3	TAG 4	TAG 5	PREV	F1, F2, F3, F4, or F5	Select the TAG position to be replaced. Once depressed, the SoftKey reverses to show it is changed.
TAG 1	TAG 2	TAG 3						
TAG 4	TAG 5	PREV						
<table border="1"> <tr><td>TUNE</td><td>TAGS</td><td>ZOOM</td></tr> <tr><td>FUNCT</td><td>MORE</td><td>CURSOR</td></tr> </table>	TUNE	TAGS	ZOOM	FUNCT	MORE	CURSOR	EXIT	Press EXIT to store changes and display Main Menu.
TUNE	TAGS	ZOOM						
FUNCT	MORE	CURSOR						

Note that there are always 5 TAG channels. You cannot increase or decrease this number.

Figure 28 - Changing the Tags within a Group Steps

3.3 Cursor Operations

Function	Sub Section	Page #
Vertical/Horizontal Cursor Toggle	3.3.1	36
Horizontal Cursor Position Reset	3.3.2	37

Table 8 - Cursor Operations

3.3.1 Vertical/Horizontal Cursor Toggle

The WindowLite PLUS has 2 cursors available. The Vertical Cursor is active most of the time. It is used primarily to indicate the current channel of interest. The Horizontal cursor is used for amplitude Peak-to-Valley (see Section 3.6.2 on page 49). Only one cursor can be active at a time.

Note that the SoftKey toggles inversely with the currently active cursor. That is, when the Vertical Cursor is active, H-CUR appears in the SoftKey menu. Conversely, when the Horizontal Cursor is active V-CUR is displayed. Thus the SoftKey is always set for the alternate selection.

The following scenario shows how to toggle the cursor.

SoftKey Menu	Press Key	Results						
<table border="1" style="width: 100%; border-collapse: collapse; text-align: center;"> <tr> <td>TUNE</td> <td>TAGS</td> <td>ZOOM</td> </tr> <tr> <td>FUNCT</td> <td>MORE</td> <td>CURSOR</td> </tr> </table>	TUNE	TAGS	ZOOM	FUNCT	MORE	CURSOR	ON or EXIT	Main Menu is displayed.
TUNE	TAGS	ZOOM						
FUNCT	MORE	CURSOR						
<table border="1" style="width: 100%; border-collapse: collapse; text-align: center;"> <tr> <td>TUNE</td> <td>TAGS</td> <td>ZOOM</td> </tr> <tr> <td>FUNCT</td> <td>MORE</td> <td>CURSOR</td> </tr> </table>	TUNE	TAGS	ZOOM	FUNCT	MORE	CURSOR	F6	
TUNE	TAGS	ZOOM						
FUNCT	MORE	CURSOR						
<table border="1" style="width: 100%; border-collapse: collapse; text-align: center;"> <tr> <td>H-CUR</td> <td></td> <td></td> </tr> <tr> <td></td> <td></td> <td>PREV</td> </tr> </table>	H-CUR					PREV	F1	Vertical / Horizontal Cursor is toggled.
H-CUR								
		PREV						
<table border="1" style="width: 100%; border-collapse: collapse; text-align: center;"> <tr> <td>V-CUR</td> <td></td> <td>RESET</td> </tr> <tr> <td></td> <td></td> <td>PREV</td> </tr> </table>	V-CUR		RESET			PREV	F6	
V-CUR		RESET						
		PREV						

Figure 29 - Vertical/Horizontal Cursor Toggle Steps

3.3.2 Horizontal Cursor Position/Reset

When the Horizontal Cursor is active, provision is made to measure the difference of the cursor from a base value. The RESET command gives the user a method for setting the base value to the current cursor position.

This scenario shows how to reset the Horizontal Cursor base value.

SoftKey Menu	Press Key	Results						
<table border="1" style="width: 100%; border-collapse: collapse;"> <tr> <td style="padding: 2px;">TUNE</td> <td style="padding: 2px;">TAGS</td> <td style="padding: 2px;">ZOOM</td> </tr> <tr> <td style="padding: 2px;">FUNCT</td> <td style="padding: 2px;">MORE</td> <td style="padding: 2px;">CURSOR</td> </tr> </table>	TUNE	TAGS	ZOOM	FUNCT	MORE	CURSOR	ON or EXIT	Main Menu is displayed.
TUNE	TAGS	ZOOM						
FUNCT	MORE	CURSOR						
<table border="1" style="width: 100%; border-collapse: collapse;"> <tr> <td style="padding: 2px;">TUNE</td> <td style="padding: 2px;">TAGS</td> <td style="padding: 2px;">ZOOM</td> </tr> <tr> <td style="padding: 2px;">FUNCT</td> <td style="padding: 2px;">MORE</td> <td style="padding: 2px;">CURSOR</td> </tr> </table>	TUNE	TAGS	ZOOM	FUNCT	MORE	CURSOR	F6	
TUNE	TAGS	ZOOM						
FUNCT	MORE	CURSOR						
<table border="1" style="width: 100%; border-collapse: collapse;"> <tr> <td style="padding: 2px;">H-CUR</td> <td style="padding: 2px;"></td> <td style="padding: 2px;"></td> </tr> <tr> <td style="padding: 2px;"></td> <td style="padding: 2px;"></td> <td style="padding: 2px;">PREV</td> </tr> </table>	H-CUR					PREV	F1	Make the horizontal cursor active.
H-CUR								
		PREV						
<table border="1" style="width: 100%; border-collapse: collapse;"> <tr> <td style="padding: 2px;">V-CUR</td> <td style="padding: 2px;"></td> <td style="padding: 2px;">RESET</td> </tr> <tr> <td style="padding: 2px;"></td> <td style="padding: 2px;"></td> <td style="padding: 2px;">PREV</td> </tr> </table>	V-CUR		RESET			PREV	Arrow Keys	Use the cursor (arrow) keys to raise or lower the Horizontal Cursor to the desired level.
V-CUR		RESET						
		PREV						
<table border="1" style="width: 100%; border-collapse: collapse;"> <tr> <td style="padding: 2px;">V-CUR</td> <td style="padding: 2px;"></td> <td style="padding: 2px;">RESET</td> </tr> <tr> <td style="padding: 2px;"></td> <td style="padding: 2px;"></td> <td style="padding: 2px;">PREV</td> </tr> </table>	V-CUR		RESET			PREV	F3	Horizontal Cursor base is reset to the current Horizontal Cursor position.
V-CUR		RESET						
		PREV						
<table border="1" style="width: 100%; border-collapse: collapse;"> <tr> <td style="padding: 2px;">V-CUR</td> <td style="padding: 2px;"></td> <td style="padding: 2px;">RESET</td> </tr> <tr> <td style="padding: 2px;"></td> <td style="padding: 2px;"></td> <td style="padding: 2px;">PREV</td> </tr> </table>	V-CUR		RESET			PREV	F6	
V-CUR		RESET						
		PREV						
RESET is displayed in the SoftKey menu only when the horizontal cursor is active.								

Figure 30 - Horizontal Cursor Position Base Value Reset Steps

3.4 Tuning to a Channel

In many of the functions of the WindowLite PLUS, it is necessary to tune to a specific channel. There are three methods for tuning to an individual channel in the WindowLite PLUS.

Tuning Method	Sub Section	Page #
By Channel No.	3.4.1	38
By Frequency	3.4.2	39
By Arrow Keys	3.4.3	39

Table 9 - Tuning to a Channel

3.4.1 Channel Number Tuning

In this method, you are tuning to a channel based on its number or name.

For those channels having names consisting only of numbers, just press the appropriate number keys followed by the enter key. **DO NOT PRESS THE DECIMAL POINT KEY.** The absence of the decimal point in the process tells the WindowLite PLUS to search for the channel name. Should you include the decimal point, the WindowLite PLUS looks for a frequency, see Section 3.4.2 on page 39 for further details.

The following scenario is used to tune to a channel number or name.

SoftKey Menu	Press Key	Results						
<table border="1"> <tr> <td>TUNE</td> <td>TAGS</td> <td>ZOOM</td> </tr> <tr> <td>FUNCT</td> <td>MORE</td> <td>CURSOR</td> </tr> </table>	TUNE	TAGS	ZOOM	FUNCT	MORE	CURSOR	ON or EXIT	Main Menu is displayed.
TUNE	TAGS	ZOOM						
FUNCT	MORE	CURSOR						
<table border="1"> <tr> <td>TUNE</td> <td>TAGS</td> <td>ZOOM</td> </tr> <tr> <td>FUNCT</td> <td>MORE</td> <td>CURSOR</td> </tr> </table>	TUNE	TAGS	ZOOM	FUNCT	MORE	CURSOR	NUM Keys and ENTER	Use the numeric keys and ENTER to select the desired channel. Do not put in a decimal point.
TUNE	TAGS	ZOOM						
FUNCT	MORE	CURSOR						
<p>Note that the absence of a decimal point implies searching for a channel by its name. Letters in a channel name are ignored during the search. The channels are searched from low to high frequency and the first channel found with the specified number in it is accepted.</p>								

Figure 31 - Channel Number Tuning

3.4.2 Channel Frequency Tuning

In this method, you are tuning to a channel based on its frequency.

Press the appropriate number keys for the frequency, *including a decimal point*, followed by the enter key. **YOU MUST INCLUDE THE DECIMAL POINT KEY.** The presence of the decimal point in the process tells the WindowLite PLUS to search for the specific frequency. If the decimal point is not included, WindowLite PLUS looks for a channel name, see Section 3.4.1 on page 38 for details.

Note that should you enter a frequency not defined within the currently active Group, the WindowLite PLUS tune to an adjacent video or audio carrier.

The following scenario is used to tune to a channel frequency.

SoftKey Menu	Press Key	Results						
<table border="1"> <tr> <td>TUNE</td> <td>TAGS</td> <td>ZOOM</td> </tr> <tr> <td>FUNCT</td> <td>MORE</td> <td>CURSOR</td> </tr> </table>	TUNE	TAGS	ZOOM	FUNCT	MORE	CURSOR	ON or EXIT	Main Menu is displayed.
TUNE	TAGS	ZOOM						
FUNCT	MORE	CURSOR						
<table border="1"> <tr> <td>TUNE</td> <td>TAGS</td> <td>ZOOM</td> </tr> <tr> <td>FUNCT</td> <td>MORE</td> <td>CURSOR</td> </tr> </table>	TUNE	TAGS	ZOOM	FUNCT	MORE	CURSOR	NUM Keys, Decimal Point, and ENTER	Use the numeric keys, decimal point, and ENTER to select the desired frequency.
TUNE	TAGS	ZOOM						
FUNCT	MORE	CURSOR						
<p>Note that inclusion of a decimal point implies searching for a channel by frequency. Should the entered frequency not be defined within the currently active Group, the video or audio carrier of a channel adjacent to that entered will be chosen.</p>								

Figure 32 - Channel Frequency Tuning Steps

3.4.3 Arrow Key Tuning

In this method, you tune to a channel based on the current cursor position.

SoftKey Menu	Press Key	Results						
<table border="1"> <tr> <td>TUNE</td> <td>TAGS</td> <td>ZOOM</td> </tr> <tr> <td>FUNCT</td> <td>MORE</td> <td>CURSOR</td> </tr> </table>	TUNE	TAGS	ZOOM	FUNCT	MORE	CURSOR	ON or EXIT	Main Menu is displayed.
TUNE	TAGS	ZOOM						
FUNCT	MORE	CURSOR						
<table border="1"> <tr> <td>TUNE</td> <td>TAGS</td> <td>ZOOM</td> </tr> <tr> <td>FUNCT</td> <td>MORE</td> <td>CURSOR</td> </tr> </table>	TUNE	TAGS	ZOOM	FUNCT	MORE	CURSOR	Arrow Keys	Use the arrow keys to move the cursor on channel at a time either left or right.
TUNE	TAGS	ZOOM						
FUNCT	MORE	CURSOR						

Figure 33 - Arrow Key Tuning Steps

3.5 Selecting Operational Mode

In order to meet the varying needs of the technician, the WindowLite PLUS has several operating modes. The following subsections address the modes shown in the table:

Mode	Sub Section	Page #
Tags Mode Select	3.5.1	41
Tune Mode Select	3.5.2	42
Zoom Mode Select	3.5.3	43
Sweep Mode Select	3.5.4	45
Automatic Time Interval Sampling Mode Select	3.5.5	46

Table 10 - Operational Modes

The examples in this manual
illustrate a Standard EIA system.

All other values are at the factory default.

3.5.1 Tags Mode Select

Tags mode enables a rapid sweep of the 5 channels identified as Tags.

To select the Tags mode:

- 1) Select TAGS at the top level of the SoftKey menus.

The following is a scenario to select Tags mode.

SoftKey Menu	Press Key	Results						
<table border="1"> <tr> <td>TUNE</td> <td>TAGS</td> <td>ZOOM</td> </tr> <tr> <td>FUNCT</td> <td>MORE</td> <td>CURSOR</td> </tr> </table>	TUNE	TAGS	ZOOM	FUNCT	MORE	CURSOR	ON or EXIT	Main Menu is displayed.
TUNE	TAGS	ZOOM						
FUNCT	MORE	CURSOR						
<table border="1"> <tr> <td>TUNE</td> <td>TAGS</td> <td>ZOOM</td> </tr> <tr> <td>FUNCT</td> <td>MORE</td> <td>CURSOR</td> </tr> </table>	TUNE	TAGS	ZOOM	FUNCT	MORE	CURSOR	F2	Tags mode is entered.
TUNE	TAGS	ZOOM						
FUNCT	MORE	CURSOR						

Tags Mode is a STARTUP definable parameter.

Figure 34 - Tags Mode Select Steps

Figure 35 shows the display when in Tags mode.

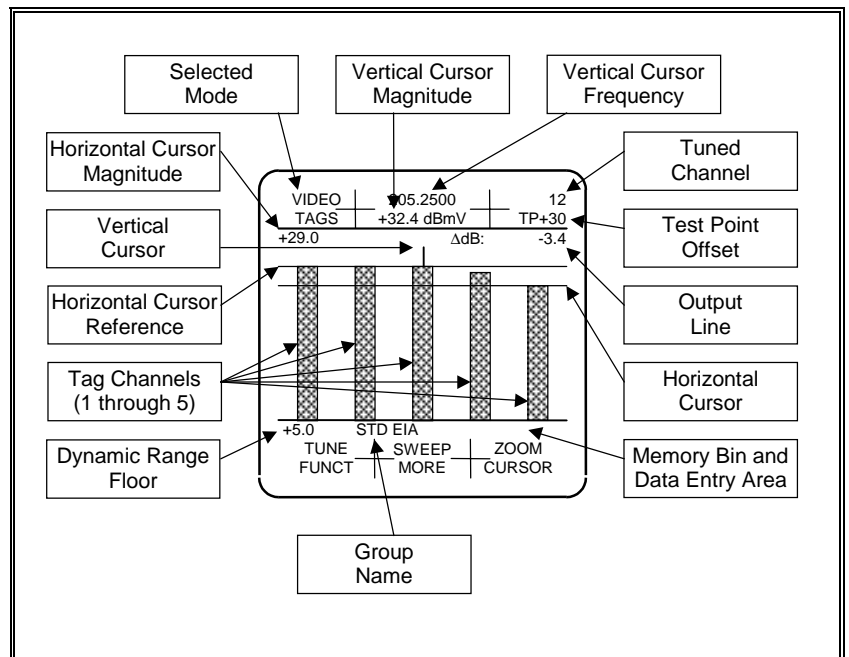

Figure 35 - Tags Mode Display

WindowLite PLUS User's Guide

Section 3 - Using the WindowLite PLUS

3.5.2 Tune Mode Select

Tune mode enables a detail sweep of a single channel.

To select the Tune mode:

- 1) Select the channel of interest.
- 2) Select TUNE at the top level of the SoftKey menus. mode.

For details on selecting a channel to observe, look at Section 3.4 beginning on page 38.

The following scenario selects tune mode.

SoftKey Menu	Press Key	Results						
<table border="1"> <tr><td>TUNE</td><td>TAGS</td><td>ZOOM</td></tr> <tr><td>FUNCT</td><td>MORE</td><td>CURSOR</td></tr> </table>	TUNE	TAGS	ZOOM	FUNCT	MORE	CURSOR	ON or EXIT	Main Menu is displayed.
TUNE	TAGS	ZOOM						
FUNCT	MORE	CURSOR						
<table border="1"> <tr><td>TUNE</td><td>TAGS</td><td>ZOOM</td></tr> <tr><td>FUNCT</td><td>MORE</td><td>CURSOR</td></tr> </table>	TUNE	TAGS	ZOOM	FUNCT	MORE	CURSOR	NUM Keys or Arrow Keys	Select the desired channel to be observed.
TUNE	TAGS	ZOOM						
FUNCT	MORE	CURSOR						
<table border="1"> <tr><td>TUNE</td><td>TAGS</td><td>ZOOM</td></tr> <tr><td>FUNCT</td><td>MORE</td><td>CURSOR</td></tr> </table>	TUNE	TAGS	ZOOM	FUNCT	MORE	CURSOR	F1	Tune Mode is entered.
TUNE	TAGS	ZOOM						
FUNCT	MORE	CURSOR						

Tune Mode is a STARTUP definable parameter.

Figure 36 - Tune Mode Select Steps

Note in this display that the current channel plus part of the upper adjacent channel is displayed. Thus, a total display of 7.75 MHz is achieved.

The arrow keys move the vertical cursor to the next 125 kHz band. As you reach the borders of the display, a shift of the display occurs, allowing you to effectively scan into the adjacent channel.

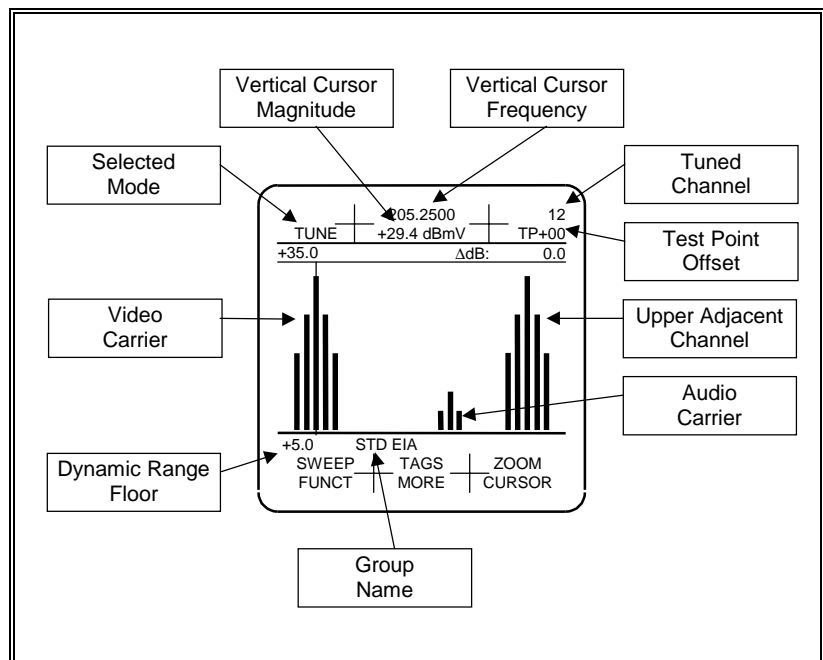

Figure 37 - Tune Mode Display

WindowLite PLUS User's Guide

Section 3 - Using the WindowLite PLUS

3.5.3 Zoom Mode Select

Zoom mode measures and displays a single channel's video and audio carriers simultaneously.

To select the Zoom mode:

- 1) Select the channel of interest.
- 2) Select ZOOM at the top level of the SoftKey menus. mode.

For details on selecting a channel to observe, look at Section 3.4 beginning on page 38.

The following scenario selects Zoom mode.

SoftKey Menu	Press Key	Results						
<table border="1"> <tr> <td>TUNE</td> <td>TAGS</td> <td>ZOOM</td> </tr> <tr> <td>FUNCT</td> <td>MORE</td> <td>CURSOR</td> </tr> </table>	TUNE	TAGS	ZOOM	FUNCT	MORE	CURSOR	ON or EXIT	Main Menu is displayed.
TUNE	TAGS	ZOOM						
FUNCT	MORE	CURSOR						
<table border="1"> <tr> <td>TUNE</td> <td>TAGS</td> <td>ZOOM</td> </tr> <tr> <td>FUNCT</td> <td>MORE</td> <td>CURSOR</td> </tr> </table>	TUNE	TAGS	ZOOM	FUNCT	MORE	CURSOR	NUM Keys or Arrow Keys	Select the channel to be observed.
TUNE	TAGS	ZOOM						
FUNCT	MORE	CURSOR						
<table border="1"> <tr> <td>TUNE</td> <td>TAGS</td> <td>ZOOM</td> </tr> <tr> <td>FUNCT</td> <td>MORE</td> <td>CURSOR</td> </tr> </table>	TUNE	TAGS	ZOOM	FUNCT	MORE	CURSOR	F3	Zoom Mode is entered.
TUNE	TAGS	ZOOM						
FUNCT	MORE	CURSOR						

Zoom Mode is a STARTUP definable parameter.

Figure 38 - Zoom Mode Select Steps

This example displays the Video and Audio carriers of channel 47. The vertical cursor amplitude (+32.4 dBmV) is that of the Video carrier. The difference between the Video and Audio (V-A) is +15.2.

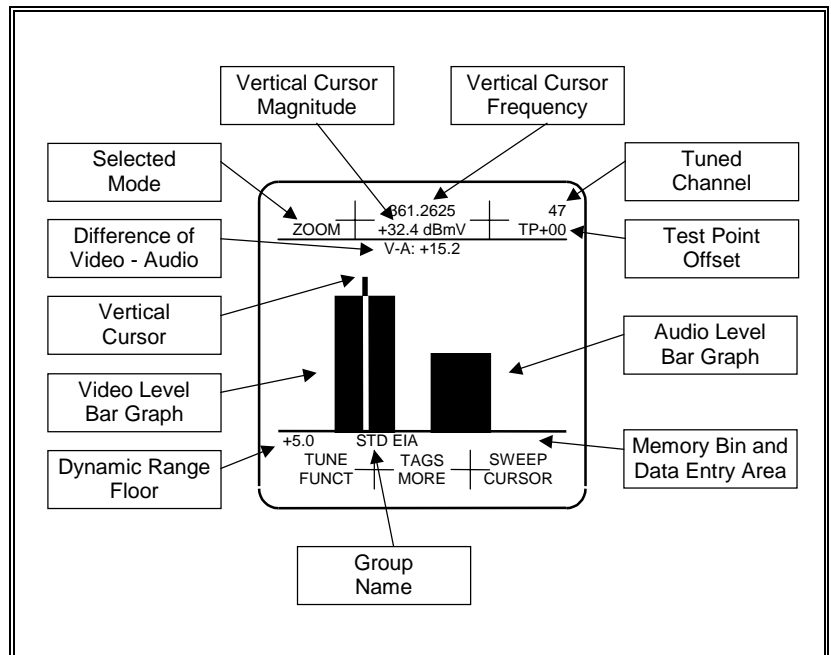

Figure 39 - Zoom Mode Display, Domestic

WindowLite PLUS User's Guide

Section 3 - Using the WindowLite PLUS

This example illustrates the display of an International group that includes a Secondary Audio carrier.

Note that an additional difference between Audio 1 and Audio 2 is provided (A-A) adjacent to the normal V-A display.

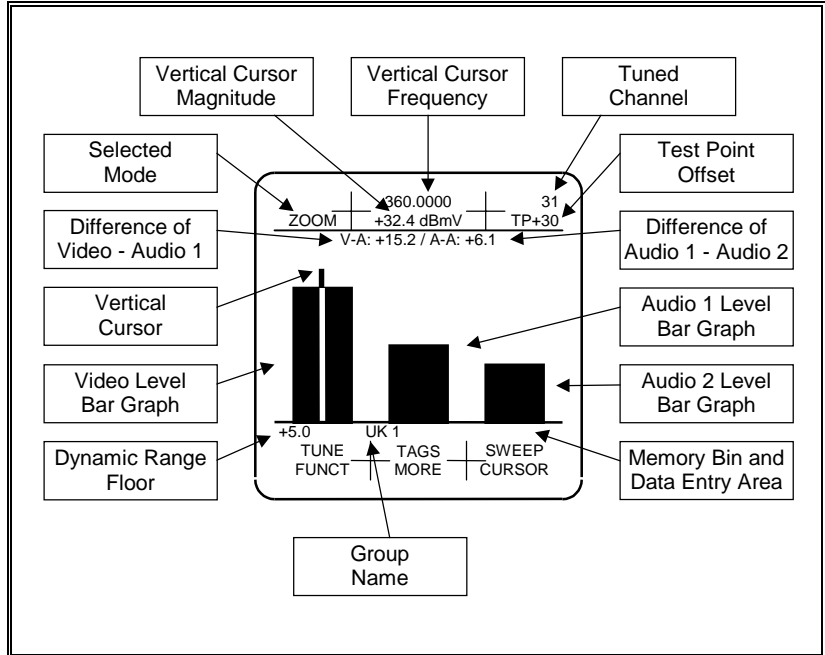

Figure 40 - Zoom Mode Display, International

WindowLite PLUS User's Guide

Section 3 - Using the WindowLite PLUS

3.5.4 Sweep Mode Select

Sweep mode measures and simultaneously displays video or audio/data levels for all frequencies defined within a Group. This is the normal startup mode for the WindowLite PLUS. If you have changed to another mode or have changed the personality of the unit so as to startup in tags mode or some other option, SWEEP appears in the top level SoftKey menu. This enables returning to the sweep mode.

To select the Sweep mode:

- 1) Select SWEEP at the top level of the SoftKey menus.

The following scenario lets you select Sweep mode.

SoftKey Menu	Press Key	Results						
<table border="1"> <tr> <td>TUNE</td> <td>SWEEP</td> <td>ZOOM</td> </tr> <tr> <td>FUNCT</td> <td>MORE</td> <td>CURSOR</td> </tr> </table>	TUNE	SWEEP	ZOOM	FUNCT	MORE	CURSOR	ON or EXIT	Main Menu is displayed. Note that the STARTUP mode is TAGS in this example.
TUNE	SWEEP	ZOOM						
FUNCT	MORE	CURSOR						
<table border="1"> <tr> <td>TUNE</td> <td>SWEEP</td> <td>ZOOM</td> </tr> <tr> <td>FUNCT</td> <td>MORE</td> <td>CURSOR</td> </tr> </table>	TUNE	SWEEP	ZOOM	FUNCT	MORE	CURSOR	F2	Select Sweep Mode.
TUNE	SWEEP	ZOOM						
FUNCT	MORE	CURSOR						

Sweep Mode is a STARTUP definable parameter.

Figure 41 - Sweep Mode Select Steps

This example shows the Sweep Mode display. The cursor is currently on Channel 23 and its level is +29.4 dBmV.

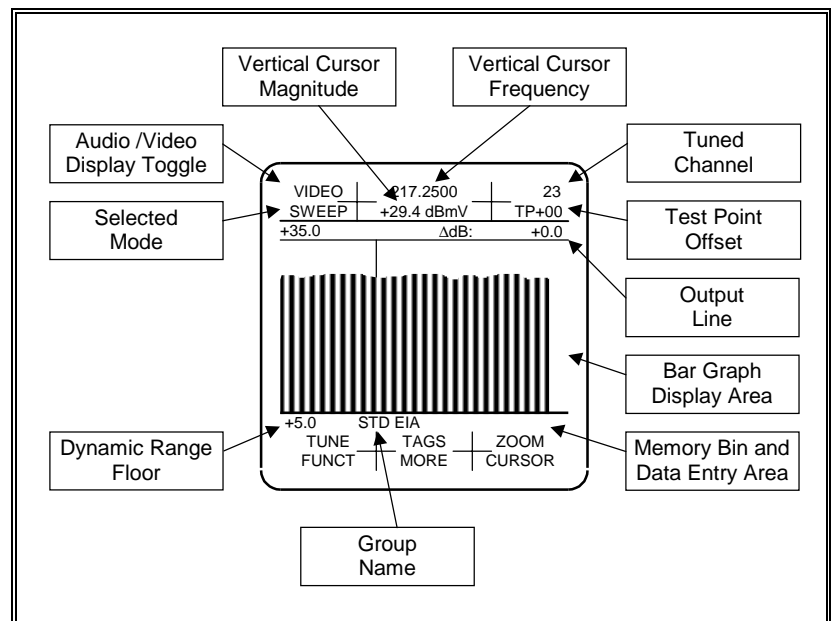

Figure 42 Sweep Mode Display

3.5.5 Automatic Time Interval Sampling (ATIS) Mode Select

This function is provided to select and deselect ATIS mode. The purpose and use of this sampling function is discussed in Section 3.6.6, on page 56. The following scenario shows how to turn ON and OFF ATIS mode.

SoftKey Menu	Press Key	Results						
<table border="1" style="width: 100%; border-collapse: collapse;"> <tr> <td style="text-align: center;">TUNE</td> <td style="text-align: center;">TAGS</td> <td style="text-align: center;">ZOOM</td> </tr> <tr> <td style="text-align: center;">FUNCT</td> <td style="text-align: center;">MORE</td> <td style="text-align: center;">CURSOR</td> </tr> </table>	TUNE	TAGS	ZOOM	FUNCT	MORE	CURSOR	ON or EXIT	Main Menu is displayed.
TUNE	TAGS	ZOOM						
FUNCT	MORE	CURSOR						
<table border="1" style="width: 100%; border-collapse: collapse;"> <tr> <td style="text-align: center;">TUNE</td> <td style="text-align: center;">TAGS</td> <td style="text-align: center;">ZOOM</td> </tr> <tr> <td style="text-align: center;">FUNCT</td> <td style="text-align: center;">MORE</td> <td style="text-align: center;">CURSOR</td> </tr> </table>	TUNE	TAGS	ZOOM	FUNCT	MORE	CURSOR	F4	
TUNE	TAGS	ZOOM						
FUNCT	MORE	CURSOR						
<table border="1" style="width: 100%; border-collapse: collapse;"> <tr> <td style="text-align: center;">CONTR+</td> <td style="text-align: center;">TIME</td> <td style="text-align: center;">TESTS</td> </tr> <tr> <td style="text-align: center;">CONTR-</td> <td style="text-align: center;">SOUND</td> <td style="text-align: center;">PREV</td> </tr> </table>	CONTR+	TIME	TESTS	CONTR-	SOUND	PREV	F3	
CONTR+	TIME	TESTS						
CONTR-	SOUND	PREV						
<table border="1" style="width: 100%; border-collapse: collapse;"> <tr> <td style="text-align: center;">CNR</td> <td style="text-align: center;">HUM</td> <td style="text-align: center;">ATIS</td> </tr> <tr> <td style="text-align: center;"></td> <td style="text-align: center;"></td> <td style="text-align: center;">PREV</td> </tr> </table>	CNR	HUM	ATIS			PREV	F3	
CNR	HUM	ATIS						
		PREV						
<table border="1" style="width: 100%; border-collapse: collapse;"> <tr> <td style="text-align: center;">TIME ON</td> <td style="text-align: center;"></td> <td style="text-align: center;">CLOCK</td> </tr> <tr> <td style="text-align: center;">INTRVAL</td> <td style="text-align: center;">GO</td> <td style="text-align: center;">PREV</td> </tr> </table>	TIME ON		CLOCK	INTRVAL	GO	PREV	F5	Depress GO to activate the ATIS mode. The unit will turn off, awaiting the first test time.
TIME ON		CLOCK						
INTRVAL	GO	PREV						

Figure 43 - Automatic Time Interval Sampling Mode Select Steps

When the ATIS mode is activated, the WindowLite will power up at the specified start time and store the first measurement. It will repeat the sequence at the specified intervals. The first measurement is stored to internal memory Bin 1, the second interval measurement is stored to Bin 2, and so forth. After the 24th interval is stored to Bin 24, the 25th interval is stored to Bin 1 and overwrites (erases) the data from the first measurement. Be sure to consider the start time, intervals, and when the test is stopped to prevent losing data from the first measurements.

Each time an ATIS session is started, the first measurement is stored to Bin 1. Any data previously stored to a bin is overwritten (erased) when new data is stored to that bin.

Data stored to memory bins during an ATIS session can be viewed at a later time, see Section 3.7.3 Memory Bin Recall, page 59.

3.6 Making Measurements

Making measurements is what the WindowLite PLUS is all about. The following sub-sections address the five most important measurements and methods for taking samples automatically at designated time intervals:

Measurement	Sub Section	Page #
Video Carrier	3.6.1	48
Peak-to-Valley	3.6.2	49
Audio Carrier	3.6.3	50
Carrier-to-Noise	3.6.4	52
Hum	3.6.5	54
Automatic Time Interval Sampling	3.6.6	56

Table 11 - Making Measurements

The examples in this manual
illustrate a Standard EIA system.
All other values are at the factory default.

WindowLite PLUS User's Guide

Section 3 - Using the WindowLite PLUS

3.6.1 Video Carrier Measurement

Video carrier measurement is the basic measurement of the unit. Simply turning the unit on and selecting the appropriate channel is all that is required.

For details on selecting a channel to observe, look at Section 3.4 which begins on page 38.

SoftKey Menu			Press Key	Results
TUNE	TAGS	ZOOM	ON or EXIT	Main Menu is displayed.
FUNCT	MORE	CURSOR		
TUNE	TAGS	ZOOM	NUM Keys or Arrow Keys	Use the numeric keys and ENTER or the arrow keys to select the channel to observe. The value is displayed on the screen.
FUNCT	MORE	CURSOR		

Figure 44 - Video Carrier Measurement Steps

In this example, channel 23 is being observed at Video frequency at 217.25 MHz. The current value of the video carrier is +29.4 dBmV.

Please note that the size of the bars in the Sweep display is dependent upon the number of channels in the Group. A Group with 35 channels has bars that are much wider than a group of 128 channels.

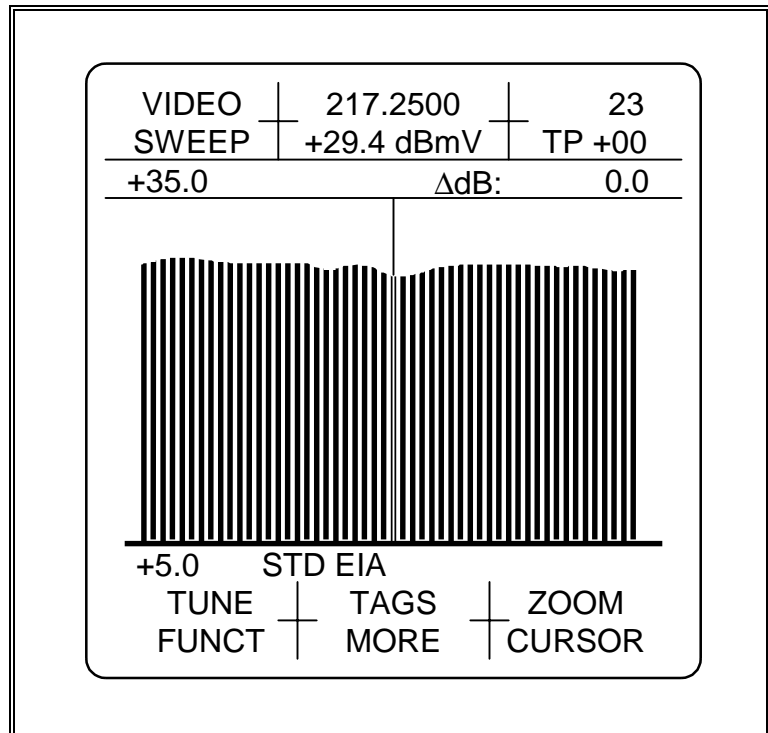

Figure 45 - Video Carrier Measurement Display

WindowLite PLUS User's Guide

Section 3 - Using the WindowLite PLUS

3.6.2 Peak- to-Valley Measurement

By definition, Peak-to-Valley measurement is determining the difference of the highest (the peak) and lowest (the valley) readings of a Group. To make a Peak-to-Valley measurement:

- 1) Make sure you are in Sweep mode.
- 2) Activate the Horizontal Cursor and place it on the valley.
- 3) Reset the Horizontal Cursor to this level.
- 4) Move the cursor to the peak and read the difference value on the screen.

SoftKey Menu	Press Key	Results						
<table border="1"> <tr><td>TUNE</td><td>TAGS</td><td>ZOOM</td></tr> <tr><td>FUNCT</td><td>MORE</td><td>CURSOR</td></tr> </table>	TUNE	TAGS	ZOOM	FUNCT	MORE	CURSOR	ON or EXIT	Main Menu is displayed. Be sure you are in the SWEEP mode.
TUNE	TAGS	ZOOM						
FUNCT	MORE	CURSOR						
<table border="1"> <tr><td>TUNE</td><td>TAGS</td><td>ZOOM</td></tr> <tr><td>FUNCT</td><td>MORE</td><td>CURSOR</td></tr> </table>	TUNE	TAGS	ZOOM	FUNCT	MORE	CURSOR	F6	
TUNE	TAGS	ZOOM						
FUNCT	MORE	CURSOR						
<table border="1"> <tr><td>H-CUR</td><td></td><td></td></tr> <tr><td></td><td></td><td>PREV</td></tr> </table>	H-CUR					PREV	F1	Press F1 as required to activate the horizontal cursor.
H-CUR								
		PREV						
<table border="1"> <tr><td>V-CUR</td><td></td><td>RESET</td></tr> <tr><td></td><td></td><td>PREV</td></tr> </table>	V-CUR		RESET			PREV	Arrow Key	Use the RIGHT ARROW key to move the horizontal cursor down to the valley.
V-CUR		RESET						
		PREV						
<table border="1"> <tr><td>V-CUR</td><td></td><td>RESET</td></tr> <tr><td></td><td></td><td>PREV</td></tr> </table>	V-CUR		RESET			PREV	F3	RESET the test value of the horizontal cursor to the valley.
V-CUR		RESET						
		PREV						
<table border="1"> <tr><td>V-CUR</td><td></td><td>RESET</td></tr> <tr><td></td><td></td><td>PREV</td></tr> </table>	V-CUR		RESET			PREV	Arrow Key	Use the LEFT ARROW key to move the horizontal cursor up to the peak. Read difference on the screen.
V-CUR		RESET						
		PREV						

Figure 46 - Peak-to-Valley Measurement Steps

(For details on using the Horizontal Cursor, see Section 3.3 which begins on page 36.)

In this example, the Peak-to-Valley measurement has been determined. Note the following:

- 1) We are in Sweep Mode.
- 2) The Horizontal Reference has been set at the valley.
- 3) The current level of the Horizontal Cursor is at the peak.
- 4) The difference or Peak-to-Valley (Δ dB:) is +4.5 dB.

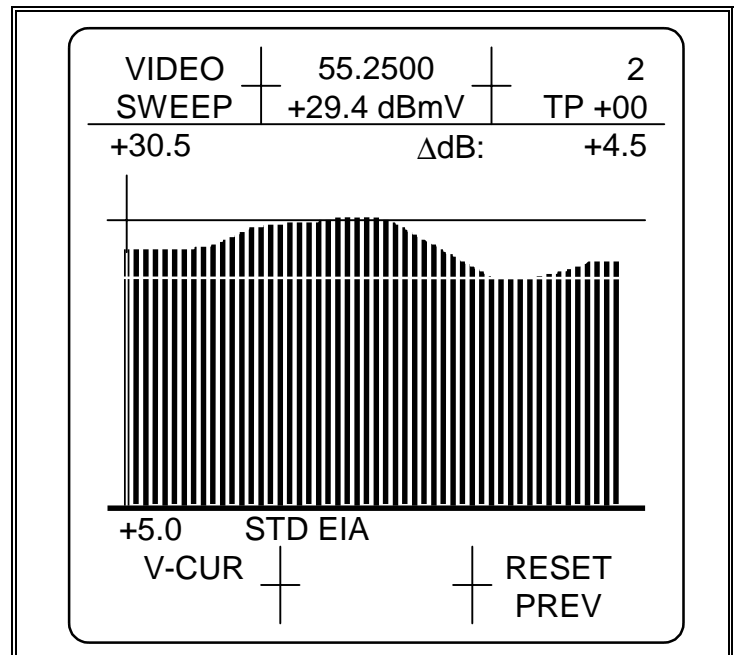

Figure 47 - Peak-to-Valley Measurement Display

3.6.3 Audio Carrier Measurement

There are several ways to observe the level of the audio carriers. The method shown displays the audio carriers in a fashion similar to the video carrier display explained in Section 3.6.1 on page 48.

To observe the audio carrier levels:

- 1) Select a channel of particular interest.
- 2) Switch to the AUDIO display mode.

For details on selecting a channel to observe, look at Section 3.4 beginning on page 38.

The following is a scenario to measure audio carrier.

<i>SoftKey Menu</i>	<i>Press Key</i>	<i>Results</i>						
<table border="1"> <tr> <td>TUNE</td> <td>TAGS</td> <td>ZOOM</td> </tr> <tr> <td>FUNCT</td> <td>MORE</td> <td>CURSOR</td> </tr> </table>	TUNE	TAGS	ZOOM	FUNCT	MORE	CURSOR	ON or EXIT	Main Menu is displayed.
TUNE	TAGS	ZOOM						
FUNCT	MORE	CURSOR						
<table border="1"> <tr> <td>TUNE</td> <td>TAGS</td> <td>ZOOM</td> </tr> <tr> <td>FUNCT</td> <td>MORE</td> <td>CURSOR</td> </tr> </table>	TUNE	TAGS	ZOOM	FUNCT	MORE	CURSOR	NUM Keys or Arrow Key	Use the numeric keys and ENTER or the arrow keys to select the channel to observe.
TUNE	TAGS	ZOOM						
FUNCT	MORE	CURSOR						
<table border="1"> <tr> <td>TUNE</td> <td>TAGS</td> <td>ZOOM</td> </tr> <tr> <td>FUNCT</td> <td>MORE</td> <td>CURSOR</td> </tr> </table>	TUNE	TAGS	ZOOM	FUNCT	MORE	CURSOR	F5	
TUNE	TAGS	ZOOM						
FUNCT	MORE	CURSOR						
<table border="1"> <tr> <td>AUDIO</td> <td>10dB</td> <td>MEMORY</td> </tr> <tr> <td>GROUP</td> <td>SETUP</td> <td>PREV</td> </tr> </table>	AUDIO	10dB	MEMORY	GROUP	SETUP	PREV	F1	The audio carriers (including FM and DATA channels) and their values are displayed.
AUDIO	10dB	MEMORY						
GROUP	SETUP	PREV						

Figure 48 - Audio Carrier Measurement Steps

FM and **DATA** channels are displayed and available for measurement only in the audio carrier mode.

WindowLite PLUS User's Guide

Section 3 - Using the WindowLite PLUS

In this example, channel 23 is being observed at Audio frequency at 221.75 MHz. The current value of the audio carrier is +14.4 dBmV.

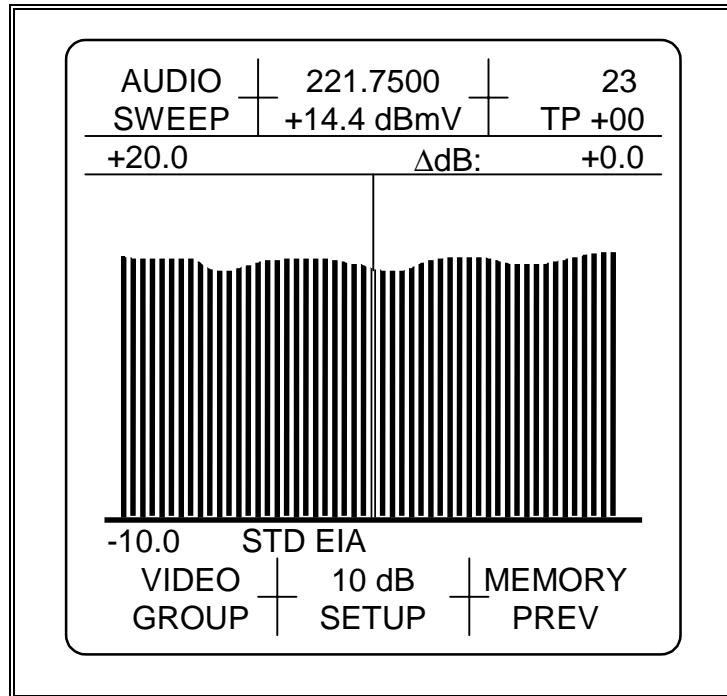

Figure 49 - Audio Carrier Measurement Display

WindowLite PLUS User's Guide

Section 3 - Using the WindowLite PLUS

3.6.4 Carrier-to-Noise Measurement

To accurately measure the System noise with the WindowLite PLUS, you must select a channel which has been processed by a modulator or processor containing a SAW filter. The modulator or processor with a SAW filter will prevent excessive video modulation in the guard band between channels. The maximum input signal level for a Carrier-to-Noise measurement is approximately +15 dBmV

(+75 dBμV). The WindowLite PLUS displays a 'reduce level' message if you exceed its maximum input level capability for this measurement.

To observe the Carrier-to-Noise Ratio:

- 1) Select the appropriate channel.
- 2) Switch to the CNR calculation mode.

For details on selecting a channel to observe, look at Section 3.4 which begins on page 38.

The following is a scenario that will accomplish this for you.

SoftKey Menu	Press Key	Results						
<table border="1"> <tr> <td>TUNE</td> <td>TAGS</td> <td>ZOOM</td> </tr> <tr> <td>FUNCT</td> <td>MORE</td> <td>CURSOR</td> </tr> </table>	TUNE	TAGS	ZOOM	FUNCT	MORE	CURSOR	ON or EXIT	Main Menu is displayed.
TUNE	TAGS	ZOOM						
FUNCT	MORE	CURSOR						
<table border="1"> <tr> <td>TUNE</td> <td>TAGS</td> <td>ZOOM</td> </tr> <tr> <td>FUNCT</td> <td>MORE</td> <td>CURSOR</td> </tr> </table>	TUNE	TAGS	ZOOM	FUNCT	MORE	CURSOR	NUM Keys or Arrow Keys	Use the numeric keys and ENTER or the arrow keys to select the channel to observe.
TUNE	TAGS	ZOOM						
FUNCT	MORE	CURSOR						
<table border="1"> <tr> <td>TUNE</td> <td>TAGS</td> <td>ZOOM</td> </tr> <tr> <td>FUNCT</td> <td>MORE</td> <td>CURSOR</td> </tr> </table>	TUNE	TAGS	ZOOM	FUNCT	MORE	CURSOR	F4	
TUNE	TAGS	ZOOM						
FUNCT	MORE	CURSOR						
<table border="1"> <tr> <td>CONTR+</td> <td>TIME</td> <td>TESTS</td> </tr> <tr> <td>CONTR-</td> <td>SOUND</td> <td>PREV</td> </tr> </table>	CONTR+	TIME	TESTS	CONTR-	SOUND	PREV	F3	
CONTR+	TIME	TESTS						
CONTR-	SOUND	PREV						
<table border="1"> <tr> <td>CNR</td> <td>HUM</td> <td>ATIS</td> </tr> <tr> <td></td> <td></td> <td>PREV</td> </tr> </table>	CNR	HUM	ATIS			PREV	F1	After a delay for calculations, the Carrier-to-Noise Ratio is displayed. Each depress causes another calculation and display.
CNR	HUM	ATIS						
		PREV						
<table border="1"> <tr> <td>CNR</td> <td>HUM</td> <td>ATIS</td> </tr> <tr> <td></td> <td></td> <td>PREV</td> </tr> </table>	CNR	HUM	ATIS			PREV	F6	
CNR	HUM	ATIS						
		PREV						
<table border="1"> <tr> <td>CNR</td> <td>HUM</td> <td>ATIS</td> </tr> <tr> <td></td> <td></td> <td>PREV</td> </tr> </table>	CNR	HUM	ATIS			PREV	F6	
CNR	HUM	ATIS						
		PREV						
<table border="1"> <tr> <td>TUNE</td> <td>TAGS</td> <td>ZOOM</td> </tr> <tr> <td>FUNCT</td> <td>MORE</td> <td>CURSOR</td> </tr> </table>	TUNE	TAGS	ZOOM	FUNCT	MORE	CURSOR		Main Menu is displayed
TUNE	TAGS	ZOOM						
FUNCT	MORE	CURSOR						

Figure 50 - Carrier-to-Noise Measurement Steps

NOTE: After a frequency (channel) is selected for the purpose of measuring CNR, it will be used as the CNR frequency when a sweep is stored to a memory bin, either manually or in the ATIS mode. The frequency will remain in effect until another frequency is selected for a CNR measurement.

WindowLite PLUS User's Guide

Section 3 - Using the WindowLite PLUS

In this example, CNR has been measured at channel 4. The resulting value is 47.1 dB.

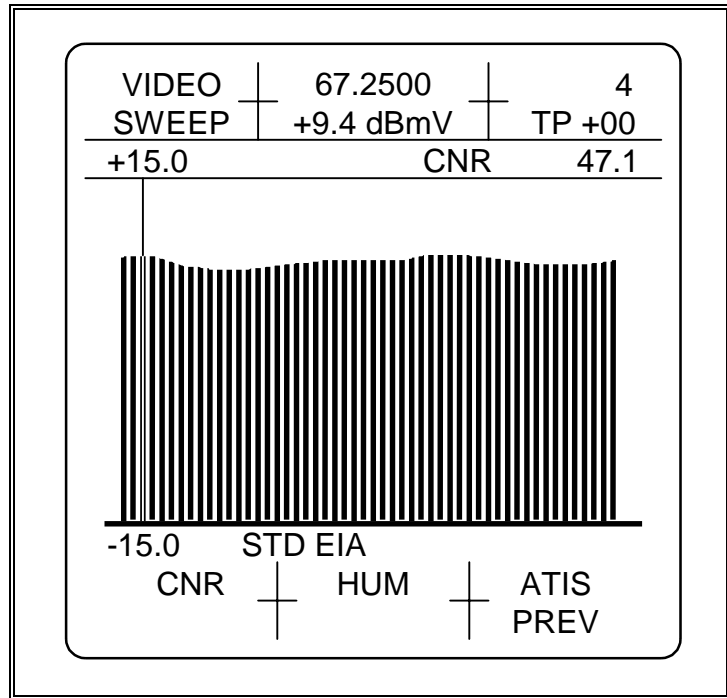

Figure 51 - Carrier-to-Noise Measurement Display

WindowLite PLUS User's Guide

Section 3 - Using the WindowLite PLUS

3.6.5 Hum Measurement

Hum must be measured on an active, full amplitude, analog television carrier. Inaccurate measurements will result from scrambled channels. The WindowLite PLUS determines the vertical sync rate of the tuned frequency and displays the appropriate hum component selections. An error message is displayed if no video modulation is found. The minimum input signal level for a hum measurement is 0 dBmV (+60 dBμV).

To observe the Hum percentage:

- 1) Select the appropriate carrier.
- 2) Switch to the HUM calculation mode.

For details on selecting a channel to observe, look at Section 3.4 beginning on page 38.

The following is a scenario to measure Hum.

SoftKey Menu	Press Key	Results						
<table border="1"> <tr> <td>TUNE</td> <td>TAGS</td> <td>ZOOM</td> </tr> <tr> <td>FUNCT</td> <td>MORE</td> <td>CURSOR</td> </tr> </table>	TUNE	TAGS	ZOOM	FUNCT	MORE	CURSOR	ON or EXIT	Main Menu is displayed.
TUNE	TAGS	ZOOM						
FUNCT	MORE	CURSOR						
<table border="1"> <tr> <td>TUNE</td> <td>TAGS</td> <td>ZOOM</td> </tr> <tr> <td>FUNCT</td> <td>MORE</td> <td>CURSOR</td> </tr> </table>	TUNE	TAGS	ZOOM	FUNCT	MORE	CURSOR	NUM Keys or Arrow Keys	Use the numeric keys and ENTER or the arrow keys to select the channel to observe.
TUNE	TAGS	ZOOM						
FUNCT	MORE	CURSOR						
<table border="1"> <tr> <td>TUNE</td> <td>TAGS</td> <td>ZOOM</td> </tr> <tr> <td>FUNCT</td> <td>MORE</td> <td>CURSOR</td> </tr> </table>	TUNE	TAGS	ZOOM	FUNCT	MORE	CURSOR	F4	
TUNE	TAGS	ZOOM						
FUNCT	MORE	CURSOR						
<table border="1"> <tr> <td>CONTR+</td> <td>TIME</td> <td>TESTS</td> </tr> <tr> <td>CONTR-</td> <td>MORE</td> <td>CURSOR</td> </tr> </table>	CONTR+	TIME	TESTS	CONTR-	MORE	CURSOR	F3	
CONTR+	TIME	TESTS						
CONTR-	MORE	CURSOR						
<table border="1"> <tr> <td>CNR</td> <td>HUM</td> <td>ATIS</td> </tr> <tr> <td></td> <td></td> <td>PREV</td> </tr> </table>	CNR	HUM	ATIS			PREV	F2	
CNR	HUM	ATIS						
		PREV						
60 Hz vertical frequency detected								
	60 HZ	ALL						
	120 HZ	PREV						
50 Hz vertical frequency detected								
50 HZ		ALL						
100 HZ		PREV						
<table border="1"> <tr> <td>TUNE</td> <td>TAGS</td> <td>ZOOM</td> </tr> <tr> <td>FUNCT</td> <td>MORE</td> <td>CURSOR</td> </tr> </table>	TUNE	TAGS	ZOOM	FUNCT	MORE	CURSOR	EXIT	Press EXIT and Main Menu is displayed.
TUNE	TAGS	ZOOM						
FUNCT	MORE	CURSOR						

Figure 52 - Hum Measurement Steps

NOTE: After a channel is selected for the purpose of measuring hum, it will be used as the hum channel when a sweep is stored to a memory bin, either manually or in the ATIS mode. The channel will remain in effect until another channel is selected for a hum measurement. ATIS and memory bin store operations use the ALL mode for hum measurements.

WindowLite PLUS User's Guide

Section 3 - Using the WindowLite PLUS

In this example, the Hum has been measured at channel 37. Its value is 1.5 percent. ALL was selected and the measurement value includes levels from all frequencies between 20 and 2,000 Hz. A vertical frequency of 60 Hz was detected.

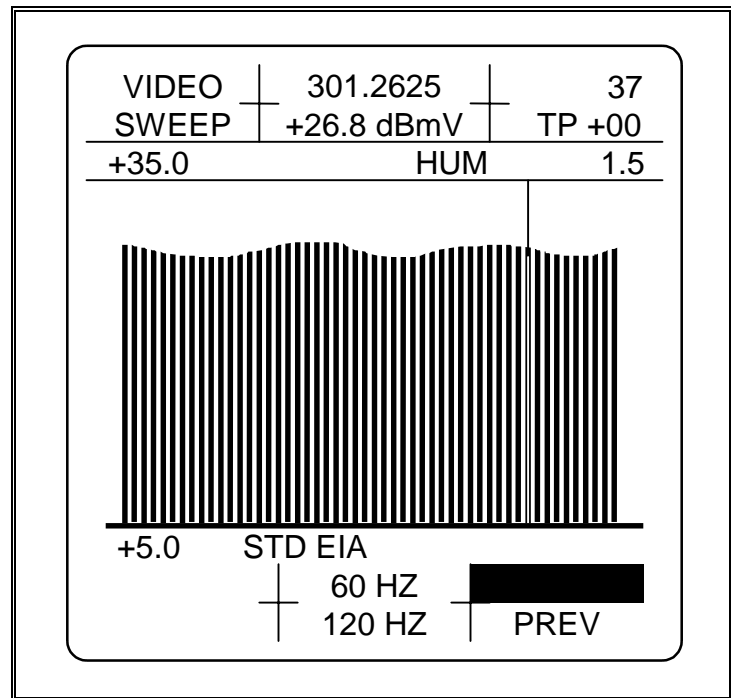

Figure 53 - Hum Measurement Display 60 Hz

In this example, the Hum has been measured at channel 24. Its value is 1.5 percent. ALL was selected and the measurement value includes levels from all frequencies between 20 and 2,000 Hz. A vertical frequency of 50 Hz was detected.

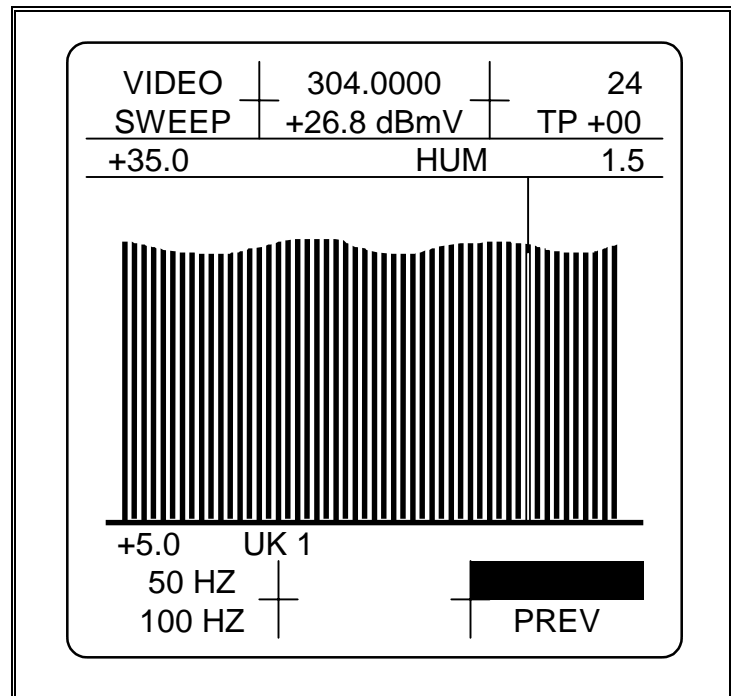

Figure 54 - Hum Measurement Display 50 Hz

WindowLite PLUS User's Guide

Section 3 - Using the WindowLite PLUS

3.6.6 Automatic Time Interval Sampling

The WindowLite PLUS provides you a method to record several of the important cable test parameters, at selected time intervals, automatically. The following parameters are stored at the specified time intervals in the non-volatile memory (bins) of an unattended WindowLite PLUS.

Date/Time (military format)	Single external ambient temperature
Single Carrier-to-Noise Ratio (see note Section 3.6.4)	Scaling information to display data
Single Channel Hum ratio (see note Section 3.6.5)	Additional Control Fields

To set the WindowLite PLUS to automatically store these parameters at specified time intervals, the operator must first enter START TIME, and INTERVAL, and then enter the ATIS mode as shown below and in Section 3.5.5, page 46.

SoftKey Menu	Press Key	Results						
<table border="1"> <tr><td>TUNE</td><td>TAGS</td><td>ZOOM</td></tr> <tr><td>FUNCT</td><td>MORE</td><td>CURSOR</td></tr> </table>	TUNE	TAGS	ZOOM	FUNCT	MORE	CURSOR	ON or EXIT	Main Menu is displayed.
TUNE	TAGS	ZOOM						
FUNCT	MORE	CURSOR						
<table border="1"> <tr><td>TUNE</td><td>TAGS</td><td>ZOOM</td></tr> <tr><td>FUNCT</td><td>MORE</td><td>CURSOR</td></tr> </table>	TUNE	TAGS	ZOOM	FUNCT	MORE	CURSOR	F4	
TUNE	TAGS	ZOOM						
FUNCT	MORE	CURSOR						
<table border="1"> <tr><td>CONTR+</td><td>TIME</td><td>TESTS</td></tr> <tr><td>CONTR-</td><td>SOUND</td><td>PREV</td></tr> </table>	CONTR+	TIME	TESTS	CONTR-	SOUND	PREV	F3	
CONTR+	TIME	TESTS						
CONTR-	SOUND	PREV						
<table border="1"> <tr><td>CNR</td><td>HUM</td><td>ATIS</td></tr> <tr><td></td><td></td><td>PREV</td></tr> </table>	CNR	HUM	ATIS			PREV	F3	
CNR	HUM	ATIS						
		PREV						
<table border="1"> <tr><td>TIME ON</td><td></td><td>CLOCK</td></tr> <tr><td>INTRVAL</td><td>GO</td><td>PREV</td></tr> </table>	TIME ON		CLOCK	INTRVAL	GO	PREV	F1	The unit displays START TIME HHMM on the input line. HHMM is the current start time.
TIME ON		CLOCK						
INTRVAL	GO	PREV						
<table border="1"> <tr><td></td><td></td><td></td></tr> <tr><td></td><td>CANCEL</td><td>PREV</td></tr> </table>					CANCEL	PREV	NUM Keys and ENTER	Use the numeric keys and ENTER to set the appropriate time.
	CANCEL	PREV						
<table border="1"> <tr><td>TIME ON</td><td></td><td>CLOCK</td></tr> <tr><td>INTRVAL</td><td>GO</td><td>PREV</td></tr> </table>	TIME ON		CLOCK	INTRVAL	GO	PREV	F4	The unit displays INTERVAL HHMM on the input line. HHMM is the current interval.
TIME ON		CLOCK						
INTRVAL	GO	PREV						
<table border="1"> <tr><td></td><td></td><td></td></tr> <tr><td></td><td>CANCEL</td><td>PREV</td></tr> </table>					CANCEL	PREV	NUM Keys and ENTER	Use the numeric keys and ENTER to set the appropriate interval. (*See below)
	CANCEL	PREV						
<table border="1"> <tr><td>TIME ON</td><td></td><td>CLOCK</td></tr> <tr><td>INTRVAL</td><td>GO</td><td>PREV</td></tr> </table>	TIME ON		CLOCK	INTRVAL	GO	PREV	F5	Depress GO to activate the ATIS mode. The unit will then power itself down.
TIME ON		CLOCK						
INTRVAL	GO	PREV						

NOTE: HH must be between 00 and 23 inclusive. MM must be between 00 and 59 inclusive. The signal level of the Carrier-to-Noise and the Hum channels must be in the range of 0 to +20 dBmV (+60 to +80 dBμV) to record measurements made during an ATIS session.

Figure 55 - Start Time and Interval for ATIS Select Steps

3.7 Using the Memory

The WindowLite PLUS has 24 memory bins. The memory bins are used to store sweep readings that the user will recall and view at a later time.

Memory Function	Sub Section	Page #
Memory Bin Store	3.7.1	57
Memory Bin Naming	3.7.2	58
Memory Bin Recall	3.7.3	59

Table 12 - Using the Memory

3.7.1 Memory Bin Store

At any time, the user can store all current sweep signal levels to any of the 24 available bins. Note that storing to a bin overwrites any previously stored data. The following parameters are stored:

Date/Time (military format)	Single external ambient temperature
Single Carrier-to-Noise Ratio (see note Section 3.6.4)	Scaling information to display data
Single Channel Hum ratio (see note Section 3.6.5)	Additional Control Fields

The following scenario shows how to store to a bin.

SoftKey Menu	Press Key	Results						
<table border="1"> <tr> <td>TUNE</td> <td>TAGS</td> <td>ZOOM</td> </tr> <tr> <td>FUNCT</td> <td>MORE</td> <td>CURSOR</td> </tr> </table>	TUNE	TAGS	ZOOM	FUNCT	MORE	CURSOR	ON or EXIT	Main Menu is displayed.
TUNE	TAGS	ZOOM						
FUNCT	MORE	CURSOR						
<table border="1"> <tr> <td>TUNE</td> <td>TAGS</td> <td>ZOOM</td> </tr> <tr> <td>FUNCT</td> <td>MORE</td> <td>CURSOR</td> </tr> </table>	TUNE	TAGS	ZOOM	FUNCT	MORE	CURSOR	F5	
TUNE	TAGS	ZOOM						
FUNCT	MORE	CURSOR						
<table border="1"> <tr> <td>AUDIO</td> <td>10dB</td> <td>MEMORY</td> </tr> <tr> <td>GROUP</td> <td>SETUP</td> <td>PREV</td> </tr> </table>	AUDIO	10dB	MEMORY	GROUP	SETUP	PREV	F3	
AUDIO	10dB	MEMORY						
GROUP	SETUP	PREV						
<table border="1"> <tr> <td>BIN 1</td> <td>BIN 2</td> <td>BIN 3</td> </tr> <tr> <td></td> <td>MORE</td> <td>PREV</td> </tr> </table>	BIN 1	BIN 2	BIN 3		MORE	PREV	F1, F2, F3 or F5	Select Bin to receive data. Use MORE to select bin 4 through 24.
BIN 1	BIN 2	BIN 3						
	MORE	PREV						
<table border="1"> <tr> <td>STORE</td> <td></td> <td>RECALL</td> </tr> <tr> <td>NAME</td> <td></td> <td>PREV</td> </tr> </table>	STORE		RECALL	NAME		PREV	F1	Store the current data in the selected Bin.
STORE		RECALL						
NAME		PREV						
<table border="1"> <tr> <td>TUNE</td> <td>TAGS</td> <td>ZOOM</td> </tr> <tr> <td>FUNCT</td> <td>MORE</td> <td>CURSOR</td> </tr> </table>	TUNE	TAGS	ZOOM	FUNCT	MORE	CURSOR	EXIT	Main Menu is displayed.
TUNE	TAGS	ZOOM						
FUNCT	MORE	CURSOR						

Figure 56 - Memory Bin Store Steps

WindowLite PLUS User's Guide

Section 3 - Using the WindowLite PLUS

3.7.2 Memory Bin Naming

The 24 bins in the WindowLite PLUS are initially labeled BIN 1 through BIN 24. You can change these names to be more meaningful to you. As in Group naming, the length of the name is limited to 7 characters, including blanks and special characters.

The following scenario will guide you through changing a bin name:

SoftKey Menu	Press Key	Results						
<table border="1"> <tr> <td>TUNE</td> <td>TAGS</td> <td>ZOOM</td> </tr> <tr> <td>FUNCT</td> <td>MORE</td> <td>CURSOR</td> </tr> </table>	TUNE	TAGS	ZOOM	FUNCT	MORE	CURSOR	ON or EXIT	Main Menu is displayed.
TUNE	TAGS	ZOOM						
FUNCT	MORE	CURSOR						
<table border="1"> <tr> <td>TUNE</td> <td>TAGS</td> <td>ZOOM</td> </tr> <tr> <td>FUNCT</td> <td>MORE</td> <td>CURSOR</td> </tr> </table>	TUNE	TAGS	ZOOM	FUNCT	MORE	CURSOR	F5	
TUNE	TAGS	ZOOM						
FUNCT	MORE	CURSOR						
<table border="1"> <tr> <td>AUDIO</td> <td>10dB</td> <td>MEMORY</td> </tr> <tr> <td>GROUP</td> <td>SETUP</td> <td>PREV</td> </tr> </table>	AUDIO	10dB	MEMORY	GROUP	SETUP	PREV	F3	
AUDIO	10dB	MEMORY						
GROUP	SETUP	PREV						
<table border="1"> <tr> <td>BIN 1</td> <td>BIN 2</td> <td>BIN 3</td> </tr> <tr> <td></td> <td>MORE</td> <td>PREV</td> </tr> </table>	BIN 1	BIN 2	BIN 3		MORE	PREV	F1, F2, F3 or F5	Select Bin to be named. Use MORE to select bins 4 through 24.
BIN 1	BIN 2	BIN 3						
	MORE	PREV						
<table border="1"> <tr> <td>STORE</td> <td></td> <td>RECALL</td> </tr> <tr> <td>NAME</td> <td></td> <td>PREV</td> </tr> </table>	STORE		RECALL	NAME		PREV	F4	
STORE		RECALL						
NAME		PREV						
<table border="1"> <tr> <td>ABCDE</td> <td>FGHIJ</td> <td>KLMNO</td> </tr> <tr> <td>CANCEL</td> <td>MORE</td> <td>PREV</td> </tr> </table>	ABCDE	FGHIJ	KLMNO	CANCEL	MORE	PREV	F1, F2, F3 F5, F6	Proceed through the steps to select the characters of the name. Press ENTER after the last character.
ABCDE	FGHIJ	KLMNO						
CANCEL	MORE	PREV						
<table border="1"> <tr> <td>TUNE</td> <td>TAGS</td> <td>ZOOM</td> </tr> <tr> <td>FUNCT</td> <td>MORE</td> <td>CURSOR</td> </tr> </table>	TUNE	TAGS	ZOOM	FUNCT	MORE	CURSOR		Main Menu is displayed.
TUNE	TAGS	ZOOM						
FUNCT	MORE	CURSOR						
Pressing the Left Arrow key will delete the last character selected.								

Figure 57 - Memory Bin Naming Steps

WindowLite PLUS User's Guide

Section 3 - Using the WindowLite PLUS

3.7.3 Memory Bin Recall

After data has been stored in a bin (see Section 3.7.1, on page 57), the user can recall the data at a later time. Once recalled, you can use the Sweep, Tags and Zoom modes to look at the recalled data. Note that Tune mode is not available, but CNR, HUM, and TIME measurements recorded when the bin was stored can be displayed after recalling bin data.

This scenario guides you through the procedure of recalling a bin.

SoftKey Menu	Press Key	Results						
<table border="1"> <tr> <td>TUNE</td> <td>TAGS</td> <td>ZOOM</td> </tr> <tr> <td>FUNCT</td> <td>MORE</td> <td>CURSOR</td> </tr> </table>	TUNE	TAGS	ZOOM	FUNCT	MORE	CURSOR	ON or EXIT	Main Menu is displayed.
TUNE	TAGS	ZOOM						
FUNCT	MORE	CURSOR						
<table border="1"> <tr> <td>TUNE</td> <td>TAGS</td> <td>ZOOM</td> </tr> <tr> <td>FUNCT</td> <td>MORE</td> <td>CURSOR</td> </tr> </table>	TUNE	TAGS	ZOOM	FUNCT	MORE	CURSOR	F5	
TUNE	TAGS	ZOOM						
FUNCT	MORE	CURSOR						
<table border="1"> <tr> <td>AUDIO</td> <td>10dB</td> <td>MEMORY</td> </tr> <tr> <td>GROUP</td> <td>SETUP</td> <td>PREV</td> </tr> </table>	AUDIO	10dB	MEMORY	GROUP	SETUP	PREV	F3	
AUDIO	10dB	MEMORY						
GROUP	SETUP	PREV						
<table border="1"> <tr> <td>BIN 1</td> <td>BIN 2</td> <td>BIN 3</td> </tr> <tr> <td></td> <td>MORE</td> <td>PREV</td> </tr> </table>	BIN 1	BIN 2	BIN 3		MORE	PREV	F1, F2, F3 or F5	Select Bin number for action. Use MORE to select bins 4 through 24.
BIN 1	BIN 2	BIN 3						
	MORE	PREV						
<table border="1"> <tr> <td>STORE</td> <td></td> <td>RECALL</td> </tr> <tr> <td>NAME</td> <td></td> <td>PREV</td> </tr> </table>	STORE		RECALL	NAME		PREV	F3	Bin is recalled and made active.
STORE		RECALL						
NAME		PREV						
<table border="1"> <tr> <td>STORE</td> <td></td> <td>RECALL</td> </tr> <tr> <td>NAME</td> <td></td> <td>PREV</td> </tr> </table>	STORE		RECALL	NAME		PREV	F6	
STORE		RECALL						
NAME		PREV						
<table border="1"> <tr> <td>BIN 1</td> <td>BIN 2</td> <td>BIN 3</td> </tr> <tr> <td></td> <td>MORE</td> <td>PREV</td> </tr> </table>	BIN 1	BIN 2	BIN 3		MORE	PREV	F6	
BIN 1	BIN 2	BIN 3						
	MORE	PREV						
<table border="1"> <tr> <td>AUDIO</td> <td>10dB</td> <td>MEMORY</td> </tr> <tr> <td>GROUP</td> <td></td> <td>PREV</td> </tr> </table>	AUDIO	10dB	MEMORY	GROUP		PREV	F6	
AUDIO	10dB	MEMORY						
GROUP		PREV						
<table border="1"> <tr> <td></td> <td>TAGS</td> <td>ZOOM</td> </tr> <tr> <td>FUNCT</td> <td>MORE</td> <td>CURSOR</td> </tr> </table>		TAGS	ZOOM	FUNCT	MORE	CURSOR		Memory Bin data is displayed with Main Menu. Review stored signal level, CNR, and HUM measurements, including the TIME data was stored. Press EXIT to return active display.
	TAGS	ZOOM						
FUNCT	MORE	CURSOR						

Note that RECALL will not be displayed in the SoftKey menu if the selected bin does not have data in it. The Main Menu will not contain TUNE when a memory bin is recalled.

Figure 58 - Memory Bin Recall Steps

WindowLite PLUS User's Guide

Section 4 - Miscellaneous

4 Miscellaneous

4.1 Format Sets

Formats are factory defined channel information sets that can be used to initialize any Group in the unit. ComSonics, Inc. currently provides 30 different Format sets that meet the needs of cable systems around the world. Others will be added as needed.

SoftKey Label	Description	Page #
AUSTRAL	Australia	61
BCST US	US Off - Air	61
BELGIUM	Belgium	62
CANADA	Canada	62
CHINA	China	63
DENMARK	Denmark	63
FRANCE	France	64
GERMANY	Germany	64
H.KONG	Hong Kong	65
HRC EIA	US HRC EIA	65
HRC HST	US HRC Historical	66
INDIA	India	66
IRC EIA	US IRC EIA	67
IRC HST	US IRC Historical	67
ISRAEL	Israel	68
ITALY	Italy	68
JAPAN	Japan	69
KOREA	Korea	69
N ZEAL	New Zealand	70
NETH 1	Netherlands 1	70
NETH 2	Netherlands 2	71
POLAND	Poland	71
REVERSE	Reverse Channel	72
STD EIA	US Standard EIA	72
STD HST	US Standard Historical	73
SWEDEN	Sweden	73
SWISS	Switzerland	74
TAIWAN	Taiwan	74
UK 1	United Kingdom 1	75
UK 2	United Kingdom 2	75

TABLE 13 - Country Format

WindowLite PLUS User's Guide

Section 4 - Miscellaneous

4.1.1 AUSTRAL - Australia

audio offset = 5.500

0	46.2500	E21	471.2500	34	569.2500	47	660.2500	60	751.2500
1	57.2500	E22	479.2500	35	576.2500	48	667.2500	61	758.2500
2	64.2500	E23	487.2500	36	583.2500	49	674.2500	62	765.2500
3	86.2500	E24	495.2500	37	590.2500	50	681.2500	63	772.2500
4	95.2500	E25	503.2500	38	597.2500	51	688.2500	64	779.2500
5	102.2500	E26	511.2500	39	604.2500	52	695.2500	65	786.2500
5-A	138.2500	E27	519.2500	40	611.2500	53	702.2500	66	793.2500
6	175.2500	28	527.2500	41	618.2500	54	709.2500	67	800.2500
7	182.2500	29	534.2500	42	625.2500	55	716.2500	68	807.2500
8	189.2500	30	541.2500	43	632.2500	56	723.2500	69	814.2500
9	196.2500	31	548.2500	44	639.2500	57	730.2500		
10	209.2500	32	555.2500	45	646.2500	58	737.2500		
11	216.2500	33	562.2500	46	653.2500	59	744.2500		

Tag Channels are:

1(57.2500), 5-A(138.2500), 11(216.2500), 35(576.2500), 54(709.2500)

4.1.2 BCST US - US Off Air

audio offset = 4.500

2	55.2500	18	495.2500	34	591.2500	50	687.2500	66	783.2500
3	61.2500	19	501.2500	35	597.2500	51	693.2500	67	789.2500
4	67.2500	20	507.2500	36	603.2500	52	699.2500	68	795.2500
5	77.2500	21	513.2500	37	609.2500	53	705.2500	69	801.2500
6	83.2500	22	519.2500	38	615.2500	54	711.2500	70	807.2500
7	175.2500	23	525.2500	39	621.2500	55	717.2500	71	813.2500
8	181.2500	24	531.2500	40	627.2500	56	723.2500	72	819.2500
9	187.2500	25	537.2500	41	633.2500	57	729.2500	73	825.2500
10	193.2500	26	543.2500	42	639.2500	58	735.2500	74	831.2500
11	199.2500	27	549.2500	43	645.2500	59	741.2500	75	837.2500
12	205.2500	28	555.2500	44	651.2500	60	747.2500	76	843.2500
13	211.2500	29	561.2500	45	657.2500	61	753.2500	77	849.2500
14	471.2500	30	567.2500	46	663.2500	62	759.2500	78	855.2500
15	477.2500	31	573.2500	47	669.2500	63	765.2500		
16	483.2500	32	579.2500	48	675.2500	64	771.2500		
17	489.2500	33	585.2500	49	681.2500	65	777.2500		

Tag Channels are:

2(55.2500), 18(495.2500), 34(591.2500), 50(687.2500), 78(855.2500)

WindowLite PLUS User's Guide

Section 4 - Miscellaneous

4.1.3 BELGIUM - Belgium

audio offset = 5.500 sec audio offset = 5.742

2	48.2500	S11	231.2500	S32	391.2500	32	559.2500	53	727.2500
3	55.2500	S12	238.2500	S33	399.2500	33	567.2500	54	735.2500
4	62.2500	S13	245.2500	S34	407.2500	34	575.2500	55	743.2500
S1	105.2500	S14	252.2500	S35	415.2500	35	583.2500	56	751.2500
S2	112.2500	S15	259.2500	S36	423.2500	36	591.2500	57	759.2500
S3	119.2500	S16	266.2500	S37	431.2500	37	599.2500	58	767.2500
S4	126.2500	S17	273.2500	S38	439.2500	38	607.2500	59	775.2500
S5	133.2500	S18	280.2500	S39	447.2500	39	615.2500	60	783.2500
S6	140.2500	S19	287.2500	S40	455.2500	40	623.2500	61	791.2500
S7	147.2500	S20	294.2500	S41	463.2500	41	631.2500	62	799.2500
S8	154.2500	S21	303.2500	21	471.2500	42	639.2500	63	807.2500
S9	161.2500	S22	311.2500	22	479.2500	43	647.2500	64	815.2500
S10	168.2500	S23	319.2500	23	487.2500	44	655.2500	65	823.2500
5	175.2500	S24	327.2500	24	495.2500	45	663.2500	66	831.2500
6	182.2500	S25	335.2500	25	503.2500	46	671.2500	67	839.2500
7	189.2500	S26	343.2500	26	511.2500	47	679.2500	68	847.2500
8	196.2500	S27	351.2500	27	519.2500	48	687.2500	69	855.2500
9	203.2500	S28	359.2500	28	527.2500	49	695.2500		
10	210.2500	S29	367.2500	29	535.2500	50	703.2500		
11	217.2500	S30	375.2500	30	543.2500	51	711.2500		
12	224.2500	S31	383.2500	31	551.2500	52	719.2500		

Tag Channels are:

3(55.2500), 5(175.2500), S16(266.2500), S39(447.2500), 30(543.2500)

4.1.4 CANADA - Canada

audio offset = 4.500

2	55.2500	23	217.2500	49	373.2500	75	529.2500	106	685.2500
3	61.2500	24	223.2500	50	379.2500	76	535.2500	107	691.2500
4	67.2500	25	229.2500	51	385.2500	77	541.2500	108	697.2500
5	77.2500	26	235.2500	52	391.2500	78	547.2500	109	703.2500
6	83.2500	27	241.2500	53	397.2500	79	553.2500	110	709.2500
95	91.2500	28	247.2500	54	403.2500	80	559.2500	111	715.2500
96	97.2500	29	253.2500	55	409.2500	81	565.2500	112	721.2500
97	103.2500	30	259.2500	56	415.2500	82	571.2500	113	727.2500
98	109.2500	31	265.2500	57	421.2500	83	577.2500	114	733.2500
99	115.2500	32	271.2500	58	427.2500	84	583.2500	115	739.2500
14	121.2500	33	277.2500	59	433.2500	85	589.2500	116	745.2500
15	127.2500	34	283.2500	60	439.2500	86	595.2500	117	751.2500
16	133.2500	35	289.2500	61	445.2500	87	601.2500	118	757.2500
17	139.2500	36	295.2500	62	451.2500	88	607.2500	119	763.2500
18	145.2500	37	301.2500	63	457.2500	89	613.2500	120	769.2500
19	151.2500	38	307.2500	64	463.2500	90	619.2500	121	775.2500
20	157.2500	39	313.2500	65	469.2500	91	625.2500	122	781.2500
21	163.2500	40	319.2500	66	475.2500	92	631.2500	123	787.2500
22	169.2500	41	325.2500	67	481.2500	93	637.2500	124	793.2500
7	175.2500	42	331.2500	68	487.2500	94	643.2500	125	799.2500
8	181.2500	43	337.2500	69	493.2500	100	649.2500	126	805.2500
9	187.2500	44	343.2500	70	499.2500	101	655.2500	127	811.2500
10	193.2500	45	349.2500	71	505.2500	102	661.2500	128	817.2500
11	199.2500	46	355.2500	72	511.2500	103	667.2500	129	823.2500
12	205.2500	47	361.2500	73	517.2500	104	673.2500		
13	211.2500	48	367.2500	74	523.2500	105	679.2500		

Tag Channels are:

4(67.2500), 99(115.2500), 27(241.2500), 40(319.2500), 51(385.2500)

WindowLite PLUS User's Guide

Section 4 - Miscellaneous

4.1.5 CHINA - China

audio offset = 6.500

DS1 49.7500	Z8 224.2500	Z27 376.2500	DS23 551.2500	DS42 743.2500
DS2 57.7500	Z9 232.2500	Z28 384.2500	DS24 559.2500	DS43 751.2500
DS3 65.7500	Z10 240.2500	Z29 392.2500	DS25 607.2500	DS44 759.2500
DS4 77.2500	Z11 248.2500	Z30 400.2500	DS26 615.2500	DS45 767.2500
DS5 85.2500	Z12 256.2500	Z31 408.2500	DS27 623.2500	DS46 775.2500
Z1 112.2500	Z13 264.2500	Z32 416.2500	DS28 631.2500	DS47 783.2500
Z2 120.2500	Z14 272.2500	Z33 424.2500	DS29 639.2500	DS48 791.2500
Z3 128.2500	Z15 280.2500	Z34 432.2500	DS30 647.2500	DS49 799.2500
Z4 136.2500	Z16 288.2500	Z35 440.2500	DS31 655.2500	DS50 807.2500
Z5 144.2500	Z17 296.2500	DS13 471.2500	DS32 663.2500	DS51 815.2500
Z6 152.2500	Z18 304.2500	DS14 479.2500	DS33 671.2500	DS52 823.2500
Z7 160.2500	Z19 312.2500	DS15 487.2500	DS34 679.2500	DS53 831.2500
DS6 168.2500	Z20 320.2500	DS16 495.2500	DS35 687.2500	DS54 839.2500
DS7 176.2500	Z21 328.2500	DS17 503.2500	DS36 695.2500	DS55 847.2500
DS8 184.2500	Z22 336.2500	DS18 511.2500	DS37 703.2500	
DS9 192.2500	Z23 344.2500	DS19 519.2500	DS38 711.2500	
DS10 200.2500	Z24 352.2500	DS20 527.2500	DS39 719.2500	
DS11 208.2500	Z25 360.2500	DS21 535.2500	DS40 727.2500	
DS12 216.2500	Z26 368.2500	DS22 543.2500	DS41 735.2500	

Tag Channels are:

DS2(57.7500), DS7(176.2500), Z15(280.2500), DS15(487.2500), DS27(623.2500)

4.1.6 DENMARK - Denmark

audio offset = 5.500 sec audio offset = 5.850

2 48.2500	99.0 99.0000	8 196.2500	S38 439.2500	46 671.2500
3 55.2500	99.5 99.5000	9 203.2500	21 471.2500	47 679.2500
4 62.2500	100. 100.0000	10 210.2500	22 479.2500	48 687.2500
87.5 87.5000	1005 100.5000	11 217.2500	23 487.2500	49 695.2500
88.0 88.0000	101. 101.0000	12 224.2500	24 495.2500	50 703.2500
88.5 88.5000	1015 101.5000	S11 231.2500	25 503.2500	51 711.2500
89.0 89.0000	102. 102.0000	S13 245.2500	26 511.2500	52 719.2500
89.5 89.5000	1025 102.5000	S14 252.2500	27 519.2500	53 727.2500
90.0 90.0000	103. 103.0000	S15 259.2500	28 527.2500	54 735.2500
90.5 90.5000	1035 103.5000	S16 266.2500	29 535.2500	55 743.2500
91.0 91.0000	104. 104.0000	S17 273.2500	30 543.2500	56 751.2500
91.5 91.5000	1045 104.5000	S18 280.2500	31 551.2500	57 759.2500
92.0 92.0000	105. 105.0000	S19 287.2500	32 559.2500	58 767.2500
92.5 92.5000	1055 105.5000	S20 294.2500	33 567.2500	59 775.2500
93.0 93.0000	106. 106.0000	S21 303.2500	34 575.2500	60 783.2500
93.5 93.5000	1065 106.5000	S22 311.2500	35 583.2500	61 791.2500
94.0 94.0000	107. 107.0000	S23 319.2500	36 591.2500	62 799.2500
94.5 94.5000	1075 107.5000	S26 343.2500	37 599.2500	63 807.2500
95.0 95.0000	108. 108.0000	S27 351.2500	38 607.2500	64 815.2500
95.5 95.5000	S7 147.2500	S28 359.2500	39 615.2500	65 823.2500
96.0 96.0000	S8 154.2500	S29 367.2500	40 623.2500	66 831.2500
96.5 96.5000	S9 161.2500	S30 375.2500	41 631.2500	67 839.2500
97.0 97.0000	S10 168.2500	S31 383.2500	42 639.2500	68 847.2500
97.5 97.5000	5 175.2500	S32 391.2500	43 647.2500	69 855.2500
98.0 98.0000	6 182.2500	S35 415.2500	44 655.2500	
98.5 98.5000	7 189.2500	S36 423.2500	45 663.2500	

Tag Channels are:

2(48.2500), 12(224.2500), S20(294.2500), 21(471.2500), 61(791.2500)

WindowLite PLUS User's Guide

Section 4 - Miscellaneous

4.1.7 FRANCE - France

audio offset = 6.500 sec audio offset = 6.742

5 176.0000	D5 351.2500	30 543.2500	44 655.2500	58 767.2500
6 184.0000	D6 363.2500	31 551.2500	45 663.2500	59 775.2500
7 192.0000	D7 375.2500	32 559.2500	46 671.2500	60 783.2500
8 200.0000	D8 387.2500	33 567.2500	47 679.2500	61 791.2500
9 208.0000	D9 399.2500	34 575.2500	48 687.2500	62 799.2500
10 216.0000	21 471.2500	35 583.2500	49 695.2500	63 807.2500
11 224.0000	22 479.2500	36 591.2500	50 703.2500	64 815.2500
12 232.0000	23 487.2500	37 599.2500	51 711.2500	65 823.2500
13 240.0000	24 495.2500	38 607.2500	52 719.2500	66 831.2500
14 288.0000	25 503.2500	39 615.2500	53 727.2500	67 839.2500
D1 303.2500	26 511.2500	40 623.2500	54 735.2500	68 847.2500
D2 315.2500	27 519.2500	41 631.2500	55 743.2500	
D3 327.2500	28 527.2500	42 639.2500	56 751.2500	
D4 339.2500	29 535.2500	43 647.2500	57 759.2500	

Tag Channels are:

6(184.0000), D4(339.2500), 28(527.2500), 51(711.2500), 63(807.2500)

4.1.8 GERMANY - Germany

audio offset = 5.500 sec audio offset = 5.742

2 48.2500	S11 231.2500	S32 391.2500	32 559.2500	53 727.2500
3 55.2500	S12 238.2500	S33 399.2500	33 567.2500	54 735.2500
4 62.2500	S13 245.2500	S34 407.2500	34 575.2500	55 743.2500
S1 105.2500	S14 252.2500	S35 415.2500	35 583.2500	56 751.2500
S2 112.2500	S15 259.2500	S36 423.2500	36 591.2500	57 759.2500
S3 119.2500	S16 266.2500	S37 431.2500	37 599.2500	58 767.2500
S4 126.2500	S17 273.2500	S38 439.2500	38 607.2500	59 775.2500
S5 133.2500	S18 280.2500	S39 447.2500	39 615.2500	60 783.2500
S6 140.2500	S19 287.2500	S40 455.2500	40 623.2500	61 791.2500
S7 147.2500	S20 294.2500	S41 463.2500	41 631.2500	62 799.2500
S8 154.2500	S21 303.2500	21 471.2500	42 639.2500	63 807.2500
S9 161.2500	S22 311.2500	22 479.2500	43 647.2500	64 815.2500
S10 168.2500	S23 319.2500	23 487.2500	44 655.2500	65 823.2500
5 175.2500	S24 327.2500	24 495.2500	45 663.2500	66 831.2500
6 182.2500	S25 335.2500	25 503.2500	46 671.2500	67 839.2500
7 189.2500	S26 343.2500	26 511.2500	47 679.2500	68 847.2500
8 196.2500	S27 351.2500	27 519.2500	48 687.2500	69 855.2500
9 203.2500	S28 359.2500	28 527.2500	49 695.2500	
10 210.2500	S29 367.2500	29 535.2500	50 703.2500	
11 217.2500	S30 375.2500	30 543.2500	51 711.2500	
12 224.2500	S31 383.2500	31 551.2500	52 719.2500	

Tag Channels are:

3(55.2500), 5(175.2500), S16(266.2500), S39(447.2500), 30(543.2500)

WindowLite PLUS User's Guide

Section 4 - Miscellaneous

4.1.9 H.KONG - Hong Kong

audio offset = 6.000 sec audio offset = 6.552

21 471.2500	30 543.2500	39 615.2500	48 687.2500	57 759.2500
22 479.2500	31 551.2500	40 623.2500	49 695.2500	58 767.2500
23 487.2500	32 559.2500	41 631.2500	50 703.2500	59 775.2500
24 495.2500	33 567.2500	42 639.2500	51 711.2500	60 783.2500
25 503.2500	34 575.2500	43 647.3500	52 719.2500	
26 511.2500	35 583.2500	44 655.2500	53 727.2500	
27 519.2500	36 591.2500	45 663.2500	54 735.2500	
28 527.2500	37 599.2500	46 671.2500	55 743.2500	
29 535.2500	38 607.2500	47 679.2500	56 751.2500	

Tag Channels are:

21(471.2500), 23(487.2500), 25(503.2500), 27(519.2500), 31(551.2500)

4.1.10 HRC EIA - US HRC EIA

audio offset = 4.500

2 54.0027	13 210.0105	48 366.0183	74 522.0261	105 678.0339
3 60.0030	23 216.0108	49 372.0186	75 528.0264	106 684.0342
4 66.0033	24 222.0111	50 378.0189	76 534.0267	107 690.0345
1 72.0036	25 228.0114	51 384.0192	77 540.0270	108 696.0348
5 78.0039	26 234.0117	52 390.0195	78 546.0273	109 702.0351
6 84.0042	27 240.0120	53 396.0198	79 552.0276	110 708.0354
95 90.0045	28 246.0123	54 402.0201	80 558.0279	111 714.0357
96 96.0048	29 252.0126	55 408.0204	81 564.0282	112 720.0360
97 102.0051	30 258.0129	56 414.0207	82 570.0285	113 726.0363
98 108.0054	31 264.0132	57 420.0210	83 576.0288	114 732.0366
99 114.0057	32 270.0135	58 426.0213	84 582.0291	115 738.0369
14 120.0060	33 276.0138	59 432.0216	85 588.0294	116 744.0372
15 126.0063	34 282.0141	60 438.0219	86 594.0297	117 750.0375
16 132.0066	35 288.0144	61 444.0222	87 600.0300	118 756.0378
17 138.0069	36 294.0147	62 450.0225	88 606.0303	119 762.0381
18 144.0072	37 300.0150	63 456.0228	89 612.0306	120 768.0384
19 150.0075	38 306.0153	64 462.0231	90 618.0309	121 774.0387
20 156.0078	39 312.0156	65 468.0234	91 624.0312	122 780.0390
21 162.0081	40 318.0159	66 474.0237	92 630.0315	123 786.0393
22 168.0084	41 324.0162	67 480.0240	93 636.0318	124 792.0396
7 174.0087	42 330.0165	68 486.0243	94 642.0321	125 798.0399
8 180.0090	43 336.0168	69 492.0246	100 648.0324	126 804.0402
9 186.0093	44 342.0171	70 498.0249	101 654.0327	127 810.0405
10 192.0096	45 348.0174	71 504.0252	102 660.0330	128 816.0408
11 198.0099	46 354.0177	72 510.0255	103 666.0333	
12 204.0102	47 360.0180	73 516.0258	104 672.0336	

Tag Channels are:

4(66.0033), 99(114.0057), 27(240.0120), 40(318.0159), 51(384.0192)

WindowLite PLUS User's Guide

Section 4 - Miscellaneous

4.1.11 HRC HST - US HRC HISTORICAL

audio offset = 4.500

2	54.0027	13	210.0105	LL	366.0183	LLL	522.0261	105	678.0339
3	60.0030	J	216.0108	MM	372.0186	MMM	528.0264	106	684.0342
4	66.0033	K	222.0111	NN	378.0189	NNN	534.0267	107	690.0345
A-8	72.0036	L	228.0114	OO	384.0192	OOO	540.0270	108	696.0348
5	78.0039	M	234.0117	PP	390.0195	PPP	546.0273	109	702.0351
6	84.0042	N	240.0120	QQ	396.0198	QQQ	552.0276	110	708.0354
A-5	90.0045	O	246.0123	RR	402.0201	RRR	558.0279	111	714.0357
A-4	96.0048	P	252.0126	SS	408.0204	SSS	564.0282	112	720.0360
A-3	102.0051	Q	258.0129	TT	414.0207	TTT	570.0285	113	726.0363
A-2	108.0054	R	264.0132	UU	420.0210	UUU	576.0288	114	732.0366
A-1	114.0057	S	270.0135	VV	426.0213	VVV	582.0291	115	738.0369
A	120.0060	T	276.0138	WW	432.0216	WWW	588.0294	116	744.0372
B	126.0063	U	282.0141	XX	438.0219	XXX	594.0297	117	750.0375
C	132.0066	V	288.0144	YY	444.0222		87 600.0030	118	756.0378
D	138.0069	W	294.0147	ZZ	450.0225		88 606.0303	119	762.0381
E	144.0072	AA	300.0150	AAA	456.0228		89 612.0306	120	768.0384
F	150.0075	BB	306.0153	BBB	462.0231		90 618.0309	121	774.0387
G	156.0078	CC	312.0156	CCC	468.0234		91 624.0312	122	780.0390
H	162.0081	DD	318.0159	DDD	474.0237		92 630.0315	123	786.0393
I	168.0084	EE	324.0162	EEE	480.0240		93 636.0318	124	792.0396
7	174.0087	FF	330.0165	FFF	486.0243		94 642.0321	125	798.0399
8	180.0090	GG	336.0168	GGG	492.0246		100 648.0324	126	804.0402
9	186.0093	HH	342.0171	HHH	498.0249		101 654.0327	127	810.0405
10	192.0096	II	348.0174	III	504.0252		102 660.0330	128	816.0408
11	198.0099	JJ	354.0177	JJJ	510.0255		103 666.0333		
12	204.0102	KK	360.0180	KKK	516.0258		104 672.0336		

Tag Channels are:

4(66.0033), A-1(114.0057), N(240.0120), DD(318.0159), OO(384.0192)

4.1.12 INDIA - India

audio offset = 5.500 sec audio offset = 5.742

2	48.2500	S7	147.2500	S11	231.2500	S23	319.2500	S35	415.2500
3	55.2500	S8	154.2500	S12	238.2500	S24	327.2500	S36	423.2500
4	62.2500	S9	161.2500	S13	245.2500	S25	335.2500	S37	431.2500
S1'	69.2500	S10	168.2500	S14	252.2500	S26	343.2500	S38	439.2500
S2'	76.2500	5	175.2500	S15	259.2500	S27	351.2500	S39	447.2500
S3'	83.2500	6	182.2500	S16	266.2500	S28	359.2500	S40	455.2500
S1	105.2500	7	189.2500	S17	273.2500	S29	367.2500	S41	463.2500
S2	112.2500	8	196.2500	S18	280.2500	S30	375.2500		
S3	119.2500	9	203.2500	S19	287.2500	S31	383.2500		
S4	126.2500	10	210.2500	S20	294.2500	S32	391.2500		
S5	133.2500	11	217.2500	S21	303.2500	S33	399.2500		
S6	140.2500	12	224.2500	S22	311.2500	S34	407.2500		

Tag Channels are:

2(48.2500), S6(140.2500), 11(217.2500), S20(294.2500), S40(455.2500)

WindowLite PLUS User's Guide

Section 4 - Miscellaneous

4.1.13 IRC EIA - US IRC EIA

audio offset = 4.500

2	55.2625	13	211.2625	48	367.2625	74	523.2625	105	679.2625
3	61.2625	23	217.2625	49	373.2625	75	529.2625	106	685.2625
4	67.2625	24	223.2625	50	379.2625	76	535.2625	107	691.2625
1	73.2625	25	229.2625	51	385.2625	77	541.2625	108	697.2625
5	79.2625	26	235.2625	52	391.2625	78	547.2625	109	703.2625
6	85.2625	27	241.2625	53	397.2625	79	553.2625	110	709.2625
95	91.2625	28	247.2625	54	403.2625	80	559.2625	111	715.2625
96	97.2625	29	253.2625	55	409.2625	81	565.2625	112	721.2625
97	103.2625	30	259.2625	56	415.2625	82	571.2625	113	727.2625
98	109.2750	31	265.2625	57	421.2625	83	577.2625	114	733.2625
99	115.2750	32	271.2625	58	427.2625	84	583.2625	115	739.2625
14	121.2625	33	277.2625	59	433.2625	85	589.2625	116	745.2625
15	127.2625	34	283.2625	60	439.2625	86	595.2625	117	751.2625
16	133.2625	35	289.2625	61	445.2625	87	601.2625	118	757.2625
17	139.2625	36	295.2625	62	451.2625	88	607.2625	119	763.2625
18	145.2625	37	301.2625	63	457.2625	89	613.2625	120	769.2625
19	151.2625	38	307.2625	64	463.2625	90	619.2625	121	775.2625
20	157.2625	39	313.2625	65	469.2625	91	625.2625	122	781.2625
21	163.2625	40	319.2625	66	475.2625	92	631.2625	123	787.2625
22	169.2625	41	325.2625	67	481.2625	93	637.2625	124	793.2625
7	175.2625	42	331.2750	68	487.2625	94	643.2625	125	799.2625
8	181.2625	43	337.2625	69	493.2625	100	649.2625	126	805.2625
9	187.2625	44	343.2625	70	499.2625	101	655.2625	127	811.2625
10	193.2625	45	349.2625	71	505.2625	102	661.2625	128	817.2625
11	199.2625	46	355.2625	72	511.2625	103	667.2625		
12	205.2625	47	361.2625	73	517.2625	104	673.2625		

Tag Channels are:

4(67.2625), 99(115.2750), 27(241.2625), 40(319.2625), 51(385.2625)

4.1.14 IRC HST - US IRC HISTORICAL

audio offset = 4.500

2	55.2625	13	211.2625	LL	367.2625	LLL	523.2625	105	679.2625
3	61.2625	J	217.2625	MM	373.2625	MMM	529.2625	106	685.2625
4	67.2625	K	223.2625	NN	379.2625	NNN	535.2625	107	691.2625
A-8	73.2625	L	229.2625	OO	385.2625	OOO	541.2625	108	697.2625
5	79.2625	M	235.2625	PP	391.2625	PPP	547.2625	109	703.2625
6	85.2625	N	241.2625	QQ	397.2625	QQQ	553.2625	110	709.2625
A-5	91.2625	O	247.2625	RR	403.2625	RRR	559.2625	111	715.2625
A-4	97.2625	P	253.2625	SS	409.2625	SSS	565.2625	112	721.2625
A-3	103.2625	Q	259.2625	TT	415.2625	TTT	571.2625	113	727.2625
A-2	109.2750	R	265.2625	UU	421.2625	UUU	577.2625	114	733.2625
A-1	115.2750	S	271.2625	VV	427.2625	VVV	583.2625	115	739.2625
A	121.2625	T	277.2625	WW	433.2625	WWW	589.2625	116	745.2625
B	127.2625	U	283.2625	XX	439.2625	XXX	595.2625	117	751.2625
C	133.2625	V	289.2625	YY	445.2625		87 601.2625	118	757.2625
D	139.2625	W	295.2625	ZZ	451.2625		88 607.2625	119	763.2625
E	145.2625	AA	301.2625	AAA	457.2625		89 613.2625	120	769.2625
F	151.2625	BB	307.2625	BBB	463.2625		90 619.2625	121	775.2625
G	157.2625	CC	313.2625	CCC	469.2625		91 625.2625	122	781.2625
H	163.2625	DD	319.2625	DDD	475.2625		92 631.2625	123	787.2625
I	169.2625	EE	325.2625	EEE	481.2625		93 637.2625	124	793.2625
7	175.2625	FF	331.2750	FFF	487.2625		94 643.2625	125	799.2625
8	181.2625	GG	337.2625	GGG	493.2625		100 649.2625	126	805.2625
9	187.2625	HH	343.2625	HHH	499.2625		101 655.2625	127	811.2625
10	193.2625	II	349.2625	III	505.2625		102 661.2625	128	817.2625
11	199.2625	JJ	355.2625	JJJ	511.2625		103 667.2625		
12	205.2625	KK	361.2625	KKK	517.2625		104 673.2625		

Tag Channels are:

4(67.2625), A-1(115.2750), N(241.2625), DD(319.2625), OO(385.2625)

WindowLite PLUS User's Guide

Section 4 - Miscellaneous

4.1.15 ISRAEL - Israel

audio offset = 5.500 sec audio offset = 5.742

2	48.2500	S11	231.2500	S32	391.2500	32	559.2500	53	727.2500
3	55.2500	S12	238.2500	S33	399.2500	33	567.2500	54	735.2500
4	62.2500	S13	245.2500	S34	407.2500	34	575.2500	55	743.2500
S1	105.2500	S14	252.2500	S35	415.2500	35	583.2500	56	751.2500
S2	112.2500	S15	259.2500	S36	423.2500	36	591.2500	57	759.2500
S3	119.2500	S16	266.2500	S37	431.2500	37	599.2500	58	767.2500
S4	126.2500	S17	273.2500	S38	439.2500	38	607.2500	59	775.2500
S5	133.2500	S18	280.2500	S39	447.2500	39	615.2500	60	783.2500
S6	140.2500	S19	287.2500	S40	455.2500	40	623.2500	61	791.2500
S7	147.2500	S20	294.2500	S41	463.2500	41	631.2500	62	799.2500
S8	154.2500	S21	303.2500	21	471.2500	42	639.2500	63	807.2500
S9	161.2500	S22	311.2500	22	479.2500	43	647.2500	64	815.2500
S10	168.2500	S23	319.2500	23	487.2500	44	655.2500	65	823.2500
5	175.2500	S24	327.2500	24	495.2500	45	663.2500	66	831.2500
6	182.2500	S25	335.2500	25	503.2500	46	671.2500	67	839.2500
7	189.2500	S26	343.2500	26	511.2500	47	679.2500	68	847.2500
8	196.2500	S27	351.2500	27	519.2500	48	687.2500	69	855.2500
9	203.2500	S28	359.2500	28	527.2500	49	695.2500		
10	210.2500	S29	367.2500	29	535.2500	50	703.2500		
11	217.2500	S30	375.2500	30	543.2500	51	711.2500		
12	224.2500	S31	383.2500	31	551.2500	52	719.2500		

Tag Channels are:

3(55.2500), 5(175.2500), S16(266.2500), S39(447.2500), 30(543.2500)

4.1.16 ITALY - Italy

audio offset = 5.500 sec audio offset = 5.742

2	48.2500	S11	231.2500	S32	391.2500	32	559.2500	53	727.2500
3	55.2500	S12	238.2500	S33	399.2500	33	567.2500	54	735.2500
4	62.2500	S13	245.2500	S34	407.2500	34	575.2500	55	743.2500
S1	105.2500	S14	252.2500	S35	415.2500	35	583.2500	56	751.2500
S2	112.2500	S15	259.2500	S36	423.2500	36	591.2500	57	759.2500
S3	119.2500	S16	266.2500	S37	431.2500	37	599.2500	58	767.2500
S4	126.2500	S17	273.2500	S38	439.2500	38	607.2500	59	775.2500
S5	133.2500	S18	280.2500	S39	447.2500	39	615.2500	60	783.2500
S6	140.2500	S19	287.2500	S40	455.2500	40	623.2500	61	791.2500
S7	147.2500	S20	294.2500	S41	463.2500	41	631.2500	62	799.2500
S8	154.2500	S21	303.2500	21	471.2500	42	639.2500	63	807.2500
S9	161.2500	S22	311.2500	22	479.2500	43	647.2500	64	815.2500
S10	168.2500	S23	319.2500	23	487.2500	44	655.2500	65	823.2500
5	175.2500	S24	327.2500	24	495.2500	45	663.2500	66	831.2500
6	182.2500	S25	335.2500	25	503.2500	46	671.2500	67	839.2500
7	189.2500	S26	343.2500	26	511.2500	47	679.2500	68	847.2500
8	196.2500	S27	351.2500	27	519.2500	48	687.2500	69	855.2500
9	203.2500	S28	359.2500	28	527.2500	49	695.2500		
10	210.2500	S29	367.2500	29	535.2500	50	703.2500		
11	217.2500	S30	375.2500	30	543.2500	51	711.2500		
12	224.2500	S31	383.2500	31	551.2500	52	719.2500		

Tag Channels are:

3(55.2500), 5(175.2500), S16(266.2500), S39(447.2500), 30(543.2500)

WindowLite PLUS User's Guide

Section 4 - Miscellaneous

4.1.17 JAPAN - Japan

audio offset = 4.500

1	91.2500	C24	231.2500	C47	367.2500	19	507.2500	42	645.2500
2	97.2500	C25	237.2500	C48	373.2500	20	513.2500	43	651.2500
3	103.2500	C26	243.2500	C49	379.2500	21	519.2500	44	657.2500
C13	109.2500	C27	249.2500	C50	385.2500	22	525.2500	45	663.2500
C14	115.2500	C28	253.2500	C51	391.2500	23	531.2500	46	669.2500
C15	121.2500	C29	259.2500	C52	397.2500	24	537.2500	47	675.2500
C16	127.2500	C30	265.2500	C53	403.2500	25	543.2500	48	681.2500
C17	133.2500	C31	271.2500	C54	409.2500	26	549.2500	49	687.2500
C18	139.2500	C32	277.2500	C55	415.2500	27	555.2500	50	693.2500
C19	145.2500	C33	283.2500	C56	421.2500	28	561.2500	51	699.2500
C20	151.2500	C34	289.2500	C57	427.2500	29	567.2500	52	705.2500
C21	157.2500	C35	295.2500	C58	433.2500	30	573.2500	53	711.2500
C22	165.2500	C36	301.2500	C59	439.2500	31	579.2500	54	717.2500
4	171.2500	C37	307.2500	C60	445.2500	32	585.2500	55	723.2500
5	177.2500	C38	313.2500	C61	451.2500	33	591.2500	56	729.2500
6	183.2500	C39	319.2500	C62	457.2500	34	597.2500	57	735.2500
7	189.2500	C40	325.2500	C63	463.2500	35	603.2500	58	741.2500
8	193.2500	C41	331.2500	13	471.2500	36	609.2500	59	747.2500
9	199.2500	C42	337.2500	14	477.2500	37	615.2500	60	753.2500
10	205.2500	C43	343.2500	15	483.2500	38	621.2500	61	759.2500
11	211.2500	C44	349.2500	16	489.2500	39	627.2500	62	765.2500
12	217.2500	C45	355.2500	17	495.2500	40	633.2500		
C23	223.2500	C46	361.2500	18	501.2500	41	639.2500		

Tag Channels are:

2(97.2500), 4(171.2500), C27(249.2500), C50(385.2500), C62(457.2500)

4.1.18 KOREA - Korea

audio offset = 4.500

2	55.2500	21	163.2500	31	265.2500	48	367.2500	65	469.2500
3	61.2500	22	169.2500	32	271.2500	49	373.2500	66	475.2500
4	67.2500	7	175.2500	33	277.2500	50	379.2500	67	481.2500
5	77.2500	8	181.2500	34	283.2500	51	385.2500	68	487.2500
6	83.2500	9	187.2500	35	289.2500	52	391.2500	69	493.2500
95	91.2500	10	193.2500	36	295.2500	53	397.2500	70	499.2500
96	97.2500	11	199.2500	37	301.2500	54	403.2500	71	505.2500
97	103.2500	12	205.2500	38	307.2500	55	409.2500	72	511.2500
98	109.2500	13	211.2500	39	313.2500	56	415.2500	73	517.2500
99	115.2500	23	217.2500	40	319.2500	57	421.2500	74	523.2500
14	121.2500	24	223.2500	41	325.2500	58	427.2500	75	529.2500
15	127.2500	25	229.2500	42	331.2500	59	433.2500	76	535.2500
16	133.2500	26	235.2500	43	337.2500	60	439.2500	77	541.2500
17	139.2500	27	241.2500	44	343.2500	61	445.2500	78	547.2500
18	145.2500	28	247.2500	45	349.2500	62	451.2500		
19	151.2500	29	253.2500	46	355.2500	63	457.2500		
20	157.2500	30	259.2500	47	361.2500	64	463.2500		

Tag Channels are:

4(67.2500), 99(115.2500), 27(241.2500), 40(319.2500), 51(385.2500)

WindowLite PLUS User's Guide

Section 4 - Miscellaneous

4.1.19 NZEAL - New Zealand

audio offset = 5.500

1	45.2500	11	224.2500	36	591.2500	46	671.2500	56	751.2500
2	55.2500	27	519.2500	37	599.2500	47	679.2500	57	759.2500
3	62.2500	28	527.2500	38	607.2500	48	687.2500	58	767.2500
4	175.2500	29	535.2500	39	615.2500	49	695.2500	59	775.2500
5	182.2500	30	543.2500	40	623.2500	50	703.2500	60	783.2500
6	189.2500	31	551.2500	41	631.2500	51	711.2500	61	791.2500
7	196.2500	32	559.2500	42	639.2500	52	719.2500	62	799.2500
8	203.2500	33	567.2500	43	647.2500	53	727.2500		
9	210.2500	34	575.2500	44	655.2500	54	735.2500		
10	217.2500	35	582.2500	45	663.2500	55	743.2500		

Tag Channels are:

2(55.2500), 7(196.2500), 28(527.2500), 43(647.2500), 62(799.2500)

4.1.20 NETH 1 - Netherlands 1

audio offset = 5.500 sec audio offset = 5.742

K2	48.2500	M6	155.2500	B2	255.2500	B9	314.2500	B16	372.2500
K4	62.2500	M7	163.2500	B3	263.2500	B10	322.2500	B17	380.2500
M1	115.2500	K5	175.2500	B4	271.2500	B11	330.2500	B18	388.2500
M2	123.2500	K7	187.2500	B5	279.2500	B12	338.2500	B19	396.2500
M3	131.2500	K9	203.2500	B6	287.2500	B13	348.2500		
M4	139.2500	K11	217.2500	B7	295.2500	B14	356.2500		
M5	147.2500	B1	231.2500	B8	306.2500	B15	364.2500		

Tag Channels are:

K2(48.2500), M6(155.2500), B2(255.2500), B9(314.2500), B19(396.2500)

WindowLite PLUS User's Guide

Section 4 - Miscellaneous

4.1.21 NETH 2 - Netherlands 2

audio offset = 5.500 sec audio offset = 5.742

2	48.2500	S11	231.2500	S32	391.2500	32	559.2500	53	727.2500
3	55.2500	S12	238.2500	S33	399.2500	33	567.2500	54	735.2500
4	62.2500	S13	245.2500	S34	407.2500	34	575.2500	55	743.2500
S1	105.2500	S14	252.2500	S35	415.2500	35	583.2500	56	751.2500
S2	112.2500	S15	259.2500	S36	423.2500	36	591.2500	57	759.2500
S3	119.2500	S16	266.2500	S37	431.2500	37	599.2500	58	767.2500
S4	126.2500	S17	273.2500	S38	439.2500	38	607.2500	59	775.2500
S5	133.2500	S18	280.2500	S39	447.2500	39	615.2500	60	783.2500
S6	140.2500	S19	287.2500	S40	455.2500	40	623.2500	61	791.2500
S7	147.2500	S20	294.2500	S41	463.2500	41	631.2500	62	799.2500
S8	154.2500	S21	303.2500	21	471.2500	42	639.2500	63	807.2500
S9	161.2500	S22	311.2500	22	479.2500	43	647.2500	64	815.2500
S10	168.2500	S23	319.2500	23	487.2500	44	655.2500	65	823.2500
5	175.2500	S24	327.2500	24	495.2500	45	663.2500	66	831.2500
6	182.2500	S25	335.2500	25	503.2500	46	671.2500	67	839.2500
7	189.2500	S26	343.2500	26	511.2500	47	679.2500	68	847.2500
8	196.2500	S27	351.2500	27	519.2500	48	687.2500	69	855.2500
9	203.2500	S28	359.2500	28	527.2500	49	695.2500		
10	210.2500	S29	367.2500	29	535.2500	50	703.2500		
11	217.2500	S30	375.2500	30	543.2500	51	711.2500		
12	224.2500	S31	383.2500	31	551.2500	52	719.2500		

Tag Channels are:

3(55.2500), 5(175.2500), S16(266.2500), S39(447.2500), 30(543.2500)

4.1.22 POLAND - Poland

audio offset = 6.500 sec audio offset = 6.742

I	49.7500	XII	223.2500	31	551.2500	42	639.2500	53	727.2500
II	59.2500	21	471.2500	32	559.2500	43	647.3500	54	735.2500
III	77.2500	22	479.2500	33	567.2500	44	655.2500	55	743.2500
IV	85.2500	23	487.2500	34	575.2500	45	663.2500	56	751.2500
V	93.2500	24	495.2500	35	583.2500	46	671.2500	57	759.2500
VI	175.2500	25	503.2500	36	591.2500	47	679.2500	58	767.2500
VII	183.2500	26	511.2500	37	599.2500	48	687.2500	59	775.2500
VIII	191.2500	27	519.2500	38	607.2500	49	695.2500	60	783.2500
IX	199.2500	28	523.2500	39	615.2500	50	703.2500	61	791.2500
X	207.2500	29	527.2500	40	623.2500	51	711.2500		
XI	215.2500	30	543.2500	41	631.2500	52	719.2500		

Tag Channels are:

II(59.2500), VII(183.2500), 21(471.2500), 36(591.2500), 55(743.2500)

WindowLite PLUS User's Guide

Section 4 - Miscellaneous

4.1.23 REVERSE - Reverse Channel

audio offset = 4.500

T7	7.0000	T9	19.0000	T11	31.0000	T13	43.0000
T8	13.0000	T10	25.0000	T12	37.0000	T14	49.0000

Tag Channels are:

T7(7.0000), T8(13.0000), T9(19.0000), T10(25.0000), T11(31.0000)

4.1.24 STD EIA - US STD EIA

audio offset = 4.500

2	55.2500	23	217.2500	49	373.2625	75	529.2500	106	685.2500
3	61.2500	24	223.2500	50	379.2625	76	535.2500	107	691.2500
4	67.2500	25	229.2625	51	385.2625	77	541.2500	108	697.2500
5	77.2500	26	235.2625	52	391.2625	78	547.2500	109	703.2500
6	83.2500	27	241.2625	53	397.2625	79	553.2500	110	709.2500
95	91.2500	28	247.2625	54	403.2500	80	559.2500	111	715.2500
96	97.2500	29	253.2625	55	409.2500	81	565.2500	112	721.2500
97	103.2500	30	259.2625	56	415.2500	82	571.2500	113	727.2500
98	109.2750	31	265.2625	57	421.2500	83	577.2500	114	733.2500
99	115.2750	32	271.2625	58	427.2500	84	583.2500	115	739.2500
14	121.2625	33	277.2625	59	433.2500	85	589.2500	116	745.2500
15	127.2625	34	283.2625	60	439.2500	86	595.2500	117	751.2500
16	133.2625	35	289.2625	61	445.2500	87	601.2500	118	757.2500
17	139.2500	36	295.2625	62	451.2500	88	607.2500	119	763.2500
18	145.2500	37	301.2625	63	457.2500	89	613.2500	120	769.2500
19	151.2500	38	307.2625	64	463.2500	90	619.2500	121	775.2500
20	157.2500	39	313.2625	65	469.2500	91	625.2500	122	781.2500
21	163.2500	40	319.2625	66	475.2500	92	631.2500	123	787.2500
22	169.2500	41	325.2625	67	481.2500	93	637.2500	124	793.2500
7	175.2500	42	331.2750	68	487.2500	94	643.2500	125	799.2500
8	181.2500	43	337.2625	69	493.2500	100	649.2500	126	805.2500
9	187.2500	44	343.2625	70	499.2500	101	655.2500	127	811.2500
10	193.2500	45	349.2625	71	505.2500	102	661.2500	128	817.2500
11	199.2500	46	355.2625	72	511.2500	103	667.2500	129	823.2500
12	205.2500	47	361.2625	73	517.2500	104	673.2500		
13	211.2500	48	367.2625	74	523.2500	105	679.2500		

Tag Channels are:

4(67.2500), 99(115.2750), 27(241.2625), 40(319.2625), 51(385.2625)

WindowLite PLUS User's Guide

Section 4 - Miscellaneous

4.1.25 STD HST - US STD HISTORICAL

audio offset = 4.500

2	55.2500	J	217.2500	MM	373.2625	MMM	529.2500	106	685.2500
3	61.2500	K	223.2500	NN	379.2625	NNN	535.2500	107	691.2500
4	67.2500	L	229.2625	OO	385.2625	OOO	541.2500	108	697.2500
5	77.2500	M	235.2625	PP	391.2625	PPP	547.2500	109	703.2500
6	83.2500	N	241.2625	QQ	397.2625	QQQ	553.2500	110	709.2500
A-5	91.2500	O	247.2625	RR	403.2500	RRR	559.2500	111	715.2500
A-4	97.2500	P	253.2625	SS	409.2500	SSS	565.2500	112	721.2500
A-3	103.2500	Q	259.2625	TT	415.2500	TTT	571.2500	113	727.2500
A-2	109.2750	R	265.2625	UU	421.2500	UUU	577.2500	114	733.2500
A-1	115.2750	S	271.2625	VV	427.2500	VVV	583.2500	115	739.2500
A	121.2625	T	277.2625	WW	433.2500	WWW	589.2500	116	745.2500
B	127.2625	U	283.2625	XX	439.2500	XXX	595.2500	117	751.2500
C	133.2625	V	289.2625	YY	445.2500	87	601.2500	118	757.2500
D	139.2500	W	295.2625	ZZ	451.2500	88	607.2500	119	763.2500
E	145.2500	AA	301.2625	AAA	457.2500	89	613.2500	120	769.2500
F	151.2500	BB	307.2625	BBB	463.2500	90	619.2500	121	775.2500
G	157.2500	CC	313.2625	CCC	469.2500	91	625.2500	122	781.2500
H	163.2500	DD	319.2625	DDD	475.2500	92	631.2500	123	787.2500
I	169.2500	EE	325.2625	EEE	481.2500	93	637.2500	124	793.2500
7	175.2500	FF	331.2750	FFF	487.2500	94	643.2500	125	799.2500
8	181.2500	GG	337.2625	GGG	493.2500	100	649.2500	126	805.2500
9	187.2500	HH	343.2625	HHH	499.2500	101	655.2500	127	811.2500
10	193.2500	II	349.2625	III	505.2500	102	661.2500	128	817.2500
11	199.2500	JJ	355.2625	JJJ	511.2500	103	667.2500	129	823.2500
12	205.2500	KK	361.2625	KKK	517.2500	104	673.2500		
13	211.2500	LL	367.2625	LLL	523.2500	105	679.2500		

Tag Channels are:

4(67.2500), A-1(115.2750), N(241.2625), DD(319.2625), OO(385.2625)

4.1.26 SWEDEN - Sweden

audio offset = 5.500 sec audio offset = 5.742

2	48.2500	S11	231.2500	S32	391.2500	32	559.2500	53	727.2500
3	55.2500	S12	238.2500	S33	399.2500	33	567.2500	54	735.2500
4	62.2500	S13	245.2500	S34	407.2500	34	575.2500	55	743.2500
S1	105.2500	S14	252.2500	S35	415.2500	35	583.2500	56	751.2500
S2	112.2500	S15	259.2500	S36	423.2500	36	591.2500	57	759.2500
S3	119.2500	S16	266.2500	S37	431.2500	37	599.2500	58	767.2500
S4	126.2500	S17	273.2500	S38	439.2500	38	607.2500	59	775.2500
S5	133.2500	S18	280.2500	S39	447.2500	39	615.2500	60	783.2500
S6	140.2500	S19	287.2500	S40	455.2500	40	623.2500	61	791.2500
S7	147.2500	S20	294.2500	S41	463.2500	41	631.2500	62	799.2500
S8	154.2500	S21	303.2500	21	471.2500	42	639.2500	63	807.2500
S9	161.2500	S22	311.2500	22	479.2500	43	647.2500	64	815.2500
S10	168.2500	S23	319.2500	23	487.2500	44	655.2500	65	823.2500
5	175.2500	S24	327.2500	24	495.2500	45	663.2500	66	831.2500
6	182.2500	S25	335.2500	25	503.2500	46	671.2500	67	839.2500
7	189.2500	S26	343.2500	26	511.2500	47	679.2500	68	847.2500
8	196.2500	S27	351.2500	27	519.2500	48	687.2500	69	855.2500
9	203.2500	S28	359.2500	28	527.2500	49	695.2500		
10	210.2500	S29	367.2500	29	535.2500	50	703.2500		
11	217.2500	S30	375.2500	30	543.2500	51	711.2500		
12	224.2500	S31	383.2500	31	551.2500	52	719.2500		

Tag Channels are:

3(55.2500), 5(175.2500), S16(266.2500), S39(447.2500), 30(543.2500)

WindowLite PLUS User's Guide

Section 4 - Miscellaneous

4.1.27 SWISS - Switzerland

audio offset = 5.500 sec audio offset = 5.742

2	48.2500	S11	231.2500	S32	391.2500	32	559.2500	53	727.2500
3	55.2500	S12	238.2500	S33	399.2500	33	567.2500	54	735.2500
4	62.2500	S13	245.2500	S34	407.2500	34	575.2500	55	743.2500
S1	105.2500	S14	252.2500	S35	415.2500	35	583.2500	56	751.2500
S2	112.2500	S15	259.2500	S36	423.2500	36	591.2500	57	759.2500
S3	119.2500	S16	266.2500	S37	431.2500	37	599.2500	58	767.2500
S4	126.2500	S17	273.2500	S38	439.2500	38	607.2500	59	775.2500
S5	133.2500	S18	280.2500	S39	447.2500	39	615.2500	60	783.2500
S6	140.2500	S19	287.2500	S40	455.2500	40	623.2500	61	791.2500
S7	147.2500	S20	294.2500	S41	463.2500	41	631.2500	62	799.2500
S8	154.2500	S21	303.2500	21	471.2500	42	639.2500	63	807.2500
S9	161.2500	S22	311.2500	22	479.2500	43	647.2500	64	815.2500
S10	168.2500	S23	319.2500	23	487.2500	44	655.2500	65	823.2500
5	175.2500	S24	327.2500	24	495.2500	45	663.2500	66	831.2500
6	182.2500	S25	335.2500	25	503.2500	46	671.2500	67	839.2500
7	189.2500	S26	343.2500	26	511.2500	47	679.2500	68	847.2500
8	196.2500	S27	351.2500	27	519.2500	48	687.2500	69	855.2500
9	203.2500	S28	359.2500	28	527.2500	49	695.2500		
10	210.2500	S29	367.2500	29	535.2500	50	703.2500		
11	217.2500	S30	375.2500	30	543.2500	51	711.2500		
12	224.2500	S31	383.2500	31	551.2500	52	719.2500		

Tag Channels are:

3(55.2500), 5(175.2500), S16(266.2500), S39(447.2500), 30(543.2500)

4.1.28 TAIWAN - Taiwan

audio offset = 4.500

2	55.2500	23	217.2500	49	373.2625	75	529.2500	106	685.2500
3	61.2500	24	223.2500	50	379.2625	76	535.2500	107	691.2500
4	67.2500	25	229.2625	51	385.2625	77	541.2500	108	697.2500
5	77.2500	26	235.2625	52	391.2625	78	547.2500	109	703.2500
6	83.2500	27	241.2625	53	397.2625	79	553.2500	110	709.2500
95	91.2500	28	247.2625	54	403.2500	80	559.2500	111	715.2500
96	97.2500	29	253.2625	55	409.2500	81	565.2500	112	721.2500
97	103.2500	30	259.2625	56	415.2500	82	571.2500	113	727.2500
98	109.2750	31	265.2625	57	421.2500	83	577.2500	114	733.2500
99	115.2750	32	271.2625	58	427.2500	84	583.2500	115	739.2500
14	121.2625	33	277.2625	59	433.2500	85	589.2500	116	745.2500
15	127.2625	34	283.2625	60	439.2500	86	595.2500	117	751.2500
16	133.2625	35	289.2625	61	445.2500	87	601.2500	118	757.2500
17	139.2500	36	295.2625	62	451.2500	88	607.2500	119	763.2500
18	145.2500	37	301.2625	63	457.2500	89	613.2500	120	769.2500
19	151.2500	38	307.2625	64	463.2500	90	619.2500	121	775.2500
20	157.2500	39	313.2625	65	469.2500	91	625.2500	122	781.2500
21	163.2500	40	319.2625	66	475.2500	92	631.2500	123	787.2500
22	169.2500	41	325.2625	67	481.2500	93	637.2500	124	793.2500
7	175.2500	42	331.2750	68	487.2500	94	643.2500	125	799.2500
8	181.2500	43	337.2625	69	493.2500	100	649.2500	126	805.2500
9	187.2500	44	343.2625	70	499.2500	101	655.2500	127	811.2500
10	193.2500	45	349.2625	71	505.2500	102	661.2500	128	817.2500
11	199.2500	46	355.2625	72	511.2500	103	667.2500	129	823.2500
12	205.2500	47	361.2625	73	517.2500	104	673.2500		
13	211.2500	48	367.2625	74	523.2500	105	679.2500		

Tag Channels are:

4(67.2500), 23(217.2500), 49(373.2625), 75(529.2500), 129(823.2500)

WindowLite PLUS User's Guide

Section 4 - Miscellaneous

4.1.29 UK 1 - United Kingdom 1

audio offset = 6.000 sec audio offset = 6.242

1 120.0000	12 208.0000	23 296.0000	34 384.0000	45 472.0000
2 128.0000	13 216.0000	24 304.0000	35 392.0000	46 480.0000
3 136.0000	14 224.0000	25 312.0000	36 400.0000	47 488.0000
4 144.0000	15 232.0000	26 320.0000	37 408.0000	48 496.0000
5 152.0000	16 240.0000	27 328.0000	38 416.0000	49 504.0000
6 160.0000	17 248.0000	28 336.0000	39 424.0000	50 512.0000
7 168.0000	18 256.0000	29 344.0000	40 432.0000	51 520.0000
8 176.0000	19 264.0000	30 352.0000	41 440.0000	52 528.0000
9 184.0000	20 272.0000	31 360.0000	42 448.0000	53 536.0000
10 192.0000	21 280.0000	32 368.0000	43 456.0000	54 544.0000
11 200.0000	22 288.0000	33 376.0000	44 464.0000	

Tag Channels are:

1(120.0000), 12(208.0000), 23(296.0000), 34(384.0000), 54(544.0000)

4.1.30 UK 2 - United Kingdom 2

audio offset = 6.000 sec audio offset = 6.242

A 55.2500	10 223.2500	19 319.2500	28 415.2500	U27 519.2500
2 135.2500	11 231.2500	20 343.2500	29 423.2500	U28 527.2500
3 159.2500	12 247.2500	21 351.2500	30 431.2500	U29 535.2500
4 175.2500	13 255.2500	22 359.2500	U21 471.2500	U30 543.2500
5 183.2500	14 263.2500	23 367.2500	U22 479.2500	
6 191.2500	15 271.2500	24 375.2500	U23 487.2500	
7 199.2500	16 279.2500	25 383.2500	U24 495.2500	
8 207.2500	17 287.2500	26 391.2500	U25 503.2500	
9 215.2500	18 295.2500	27 399.2500	U26 511.2500	

Tag Channels are:

A(55.2500), 2(135.2500), 16(279.2500), 24(375.2500), U30(543.2500)

WindowLite PLUS User's Guide

Section 4 - Miscellaneous

4.2 Glossary

ATIS	Automatic Time Interval Sampling is a method of recording several important cable test parameters, at intervals selected by the operator, automatically.
Balance Adjust	A flat balance adjustment used to match the WindowLite PLUS to other equipment that is perceived to be reading slightly higher or lower. This adjustment can be from -5.0 dB through +5.0 dB in 0.1 dB steps. Use this function with care!
Calibration Updating	An internal noise source allows precise, continuous calibration updating. This is a WindowLite PLUS exclusive.
Channel	One of up to 128 carriers in a Group. A channel is specified for frequency, name, and type (TV, FM, or Data).
Date Format	The date format maybe either MM/DD/YY or DD/MM/YY.
DELTA™	An option for the WindowLite PLUS that enables the user to visually compare a stored past system response to an active current system response.
Display Contrast	Setting the display lighter or darker.
Display Range Toggle	The dynamic range displayed on the screen maybe either 10 dB full scale or 30 dB full scale.
FiberLite™	Fiber Optic Powermeter Module for the WindowLite PLUS. Offers dual wavelength detection and universal mounting adapter to fit most industry standard connectors.
Formats	Formats are factory defined channel information sets that can be used to initialize any Group in the unit.
Groups	There are 6 Groups in the WindowLite PLUS. Each Group contains specific information on a set of 5 to 128 channels. In this definition, a channel is either a TV channel, an FM carrier or a data carrier. The information maintained on each channel is its name, its video carrier frequency and its audio carrier frequency. Group information may be customized by the user.
Key Beep Loudness	Personal preference of the beep loudness when a key is pressed.

WindowLite PLUS User's Guide

Section 4 - Miscellaneous

Memory Bins	The WindowLite PLUS contains 24 memory bins. These memory bins are used to store a full set of measurements, time, date, carrier-to-noise, hum, temperature, and scaling information. At any time, the user can cause the current readings of the Group being observed to be stored in any bin. The readings thus stored maybe reviewed at a later time. The memory bins are in the non-volatile memory of the unit and as such their contents are preserved when the unit is turned off.
Menu Navigator	A flowchart of operator and configuration menus
Name	A function provided for the user to change group and memory bin names to be more meaningful.
Personality	Configuring the WindowLite PLUS to specific startup parameters and user adjustments.
PrintLite™	Printer Module for the WindowLite PLUS. Generate on-site reports from data stored in the memory bins.
SnifferLite™	RF Leakage Detection Module for the WindowLite PLUS. Allows vehicle mounting with the Docking Station for leakage monitoring. Can be used with the GeoSniffer System for the automatic logging of location and RF leakage data. Hand-held operation is used to measure, detect, or correct leakage sources.
SoftKeys	Function Keys that can assume different meanings depending upon the current status of the WindowLite PLUS.
StartUp Mode Define	Setting the definable startup parameters (TUNE, TAGS, ZOOM, SWEEP mode; Group; dBmV/dBμV; Key Beep; Auto Shut Down Timer; Test Point Adjust; Balance; Display Contrast; Audio/Video Carrier Display).
Sweep Mode	A bar graph simultaneously measuring and displaying the video or audio/data levels for all frequencies defined with a Group.
Tags	Within each Group, 5 channels are designated Tags channels. These will be the only ones displayed when the WindowLite PLUS is in the Tags sweep mode. Since only 5 channels are swept, a faster display update is achieved. The channels referenced as Tags can be changed by the user.
TDRLite™	Time Domain Reflectometer Module for the WindowLite PLUS. Used as a fault detector in troubleshooting cable runs.

WindowLite PLUS User's Guide

Section 4 - Miscellaneous

Test Point Offset	Pre-programs a value to be added to the current measurement when the operator presses TP ADJ. Selectable values are: 5, 10, 15, 20, 25, or 30 dB.
Time Format	The time format is fixed to military style (24 hour).
Tune Mode	A bar graph of a detailed sweep of a single channel. The display is stepped in increments of 125 kHz and has a screen bandwidth of 7.75 MHz.
Units of Measure	Absolute measurement values may be either dBmV (1.0 millivolt reference) or dB μ V (1.0 microvolt reference) units.
WindowLite PLUS™	The first full-function, truly hand-held signal level meter for the cable television field technician designed with modular capability.
Zoom Mode	A bar graph display showing a single channel's video and audio carriers simultaneously.

4.3 European Community Declaration of Compliance



Manufacturer: ComSonics, Inc.
P.O. Box 1106
1350 Port Republic Road
Harrisonburg, VA, 22801 USA
Tel. # 540-434-5965

Product: WindowLite PLUS
Models: 100280-007
100280-006
100280-005

ComSonics, Inc. of Harrisonburg, Virginia, USA, hereby declares that the above-referenced product, to which this declaration relates, is in conformity with the provisions of:

Council Directive 89/336/EEC (May 3, 1989), on Electromagnetic Compatibility, as amended by Council Directive 92/31/EEC (April 28, 1992), and

Council Directive 73/23/EEC (February 19, 1973), on Low Voltage.

The Technical File required by these directives, including the original of this Declaration of Conformity, are maintained at the corporate headquarters of ComSonics, Inc. (as listed above) and within the European Community at ComTec Cable Accessories, Ltd., Over Industrial Park, Over, Cambridge CB4 5QE, United Kingdom.